

# PERMASPAN RW EXPANSION JOINT

ROOF TO WALL VERSION

INSTALLATION INSTRUCTIONS

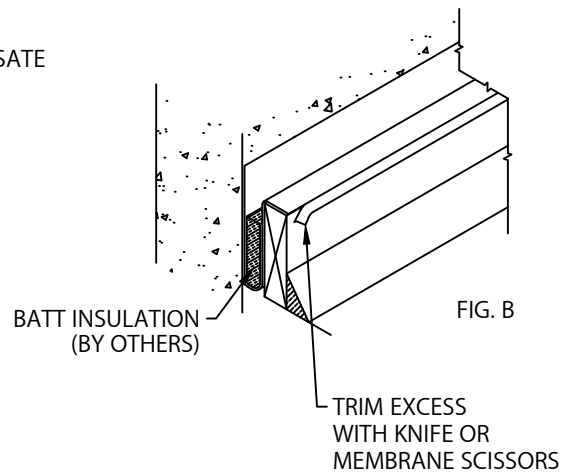
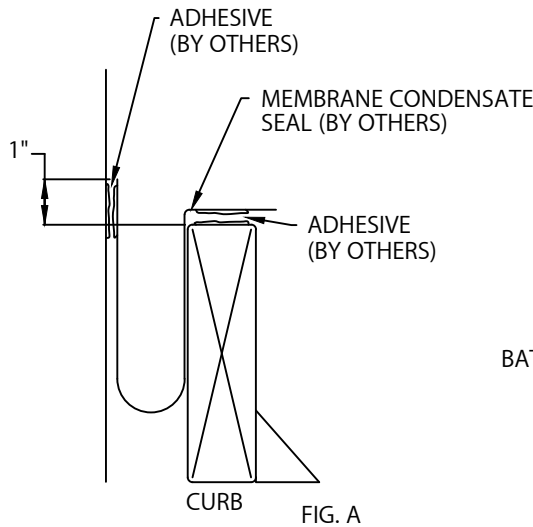

## 1. Condensation Seal

Begin the expansion joint installation by first inserting the condensation seal (by others) into the expansion joint gap between the curb and the wall, extending the pocket to a depth at least equal to the width of the expansion joint, more if allowable. Lap 6" and seal all membrane joints. Fold in the ends of the membrane seal, secure to the wood curb to a height on the wall of 1" above curb to temporarily hold the membrane in place using an adhesive (by others) (Fig. A). Trim membrane to be even with the outside edge of the curb, if necessary (Fig. B). Insert the insulation (by others) into the pocket of the membrane.

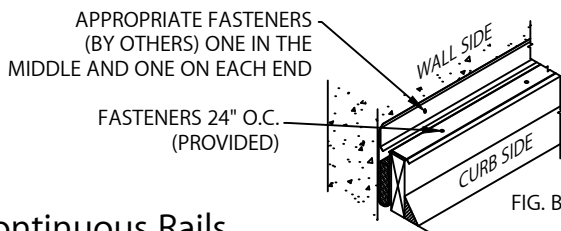
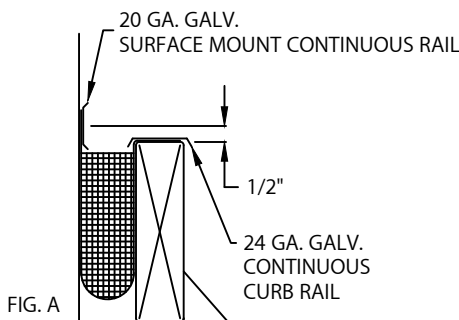

## 2. Continuous Rails

Fasten the 24 ga. galvanized continuous curb rail 24" O.C. to the top of the wood curb with provided fasteners (Fig. B). Fasten the 20 ga. galvanized surface mount continuous rail (edges facing out) to the wall (one fastener in the middle and one at each end) with an appropriate fastener (by others) suitable for substrate, with flattest head possible (see above). The center of the surface mount rail must be 1/2" above the top of the wood curb (Fig. A)

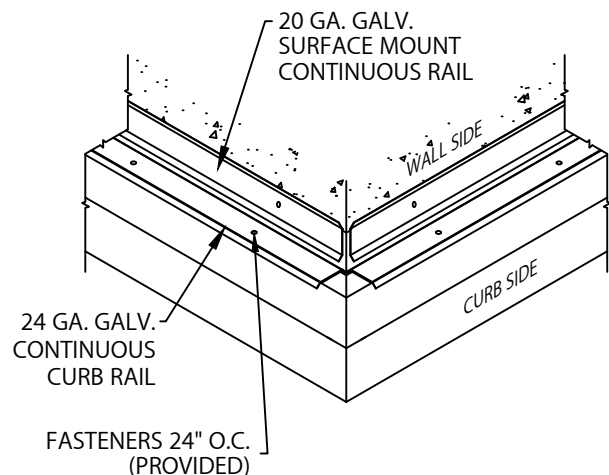

## 3. Miters

Field cut curbs at a 90° angle as shown. Follow steps 1 and 2, installing condensation seal, batt insulation and continuous rails.

# PERMASPAN RW EXPANSION JOINT

ROOF TO WALL VERSION

INSTALLATION INSTRUCTIONS

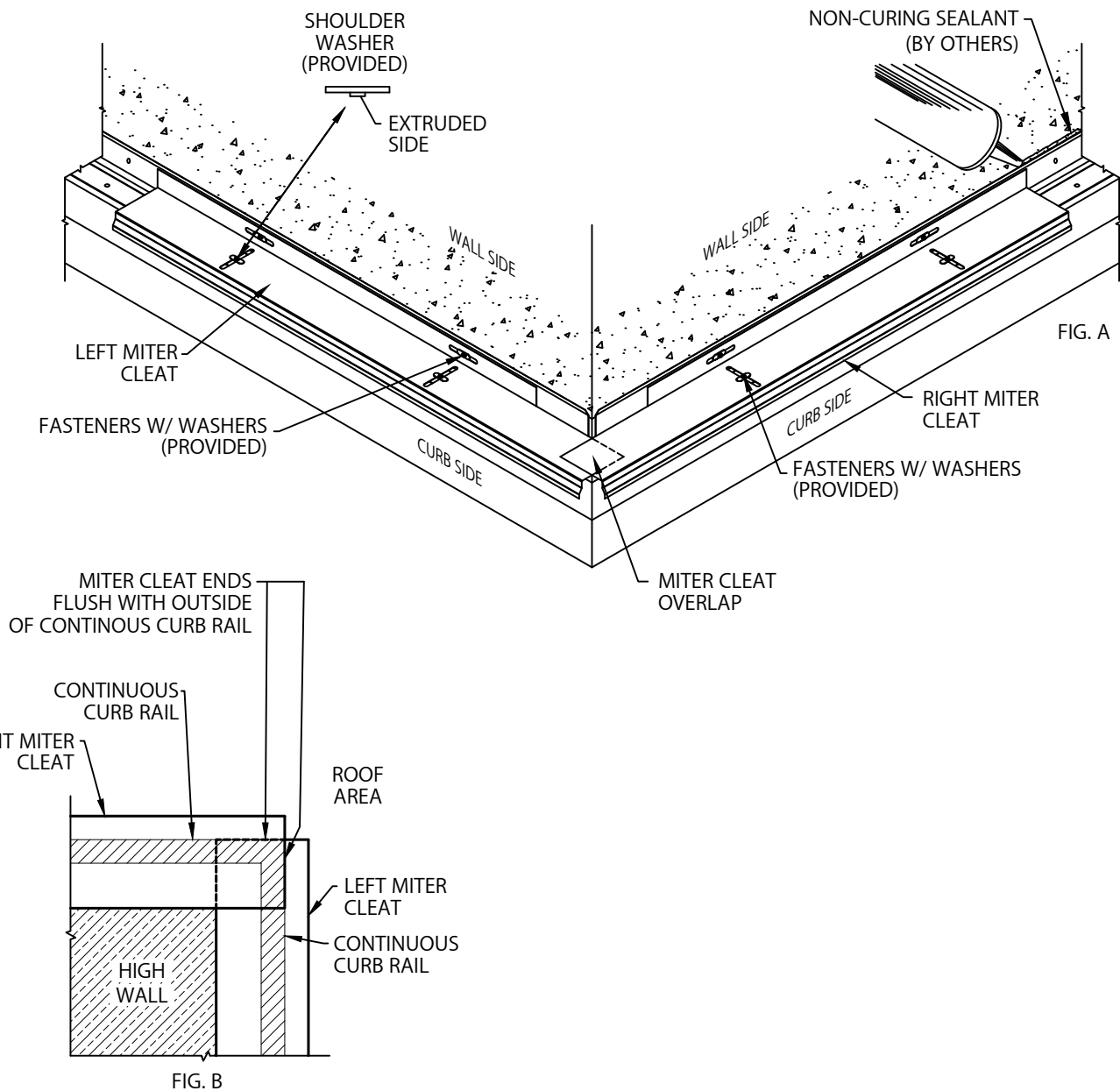

## 4. Outside Miters

Loosely lay miter cleat in place over the expansion joint curb. Position the cleat so that the vertical flange is against the wall. The cleat should extend beyond the curb (Fig. A). Cleats should be flush with outside of continuous curb rail (Fig. B) with one cleat overlapping the other at corner (Fig. A). Secure the cleat with fasteners and shouldered washers provided through the slots of continuous cleat into the wood curb and fasteners with washers through slots into wall. The washers are to be placed extruded side down approximately slot center on the wall and center of the curb. Apply non-curing sealant (by others) to the top lip of surface mount continuous rail.

DO NOT OVERDRIVE THE SCREWS INTO THE CLEAT SO THAT THE SCREWS DO NOT RESTRICT MOVEMENT.

# PERMASPAN RW EXPANSION JOINT

ROOF TO WALL VERSION

INSTALLATION INSTRUCTIONS

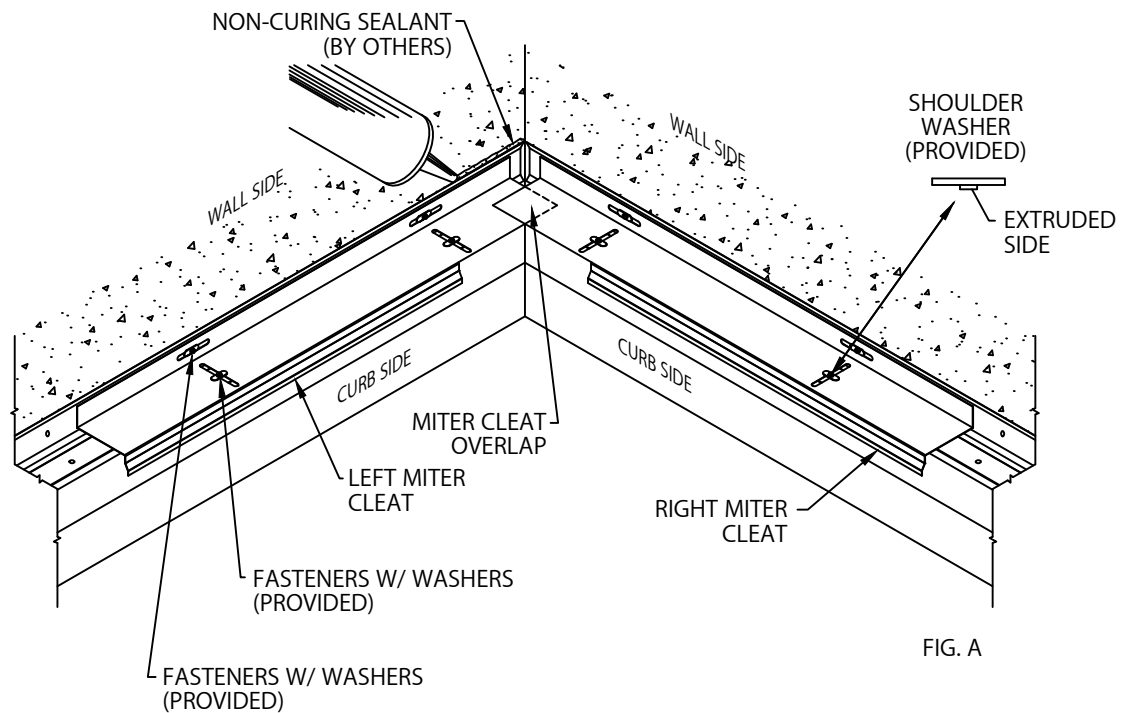

FIG. A

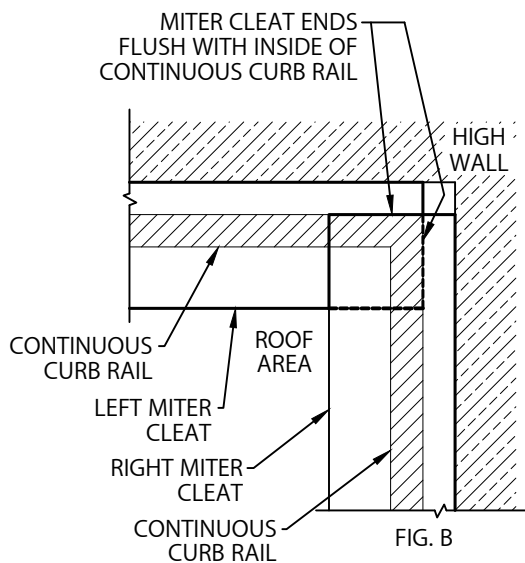

FIG. B

## 5. Inside Miters

Loosely lay miter cleat in place over the expansion joint curb. Position the cleat so that the vertical flange is against the wall. The cleat should extend beyond the curb (Fig. A). Cleats should be flush with inside of curb rail (Fig. B) with one cleat overlapping the other at corner (Fig. A). Secure the cleat with fasteners and shouldered washers provided through the slots of continuous cleat into the wood curb and fasteners with washers through slots into wall. The washers are to be placed extruded side down approximately slot center on the wall and center of the curb. Apply non-curing sealant (by others) to the top lip of surface mount continuous rail.

DO NOT OVERDRIVE THE SCREWS INTO THE CLEAT SO THAT THE SCREWS DO NOT RESTRICT MOVEMENT.

# PERMASPAN RW EXPANSION JOINT

ROOF TO WALL VERSION

INSTALLATION INSTRUCTIONS

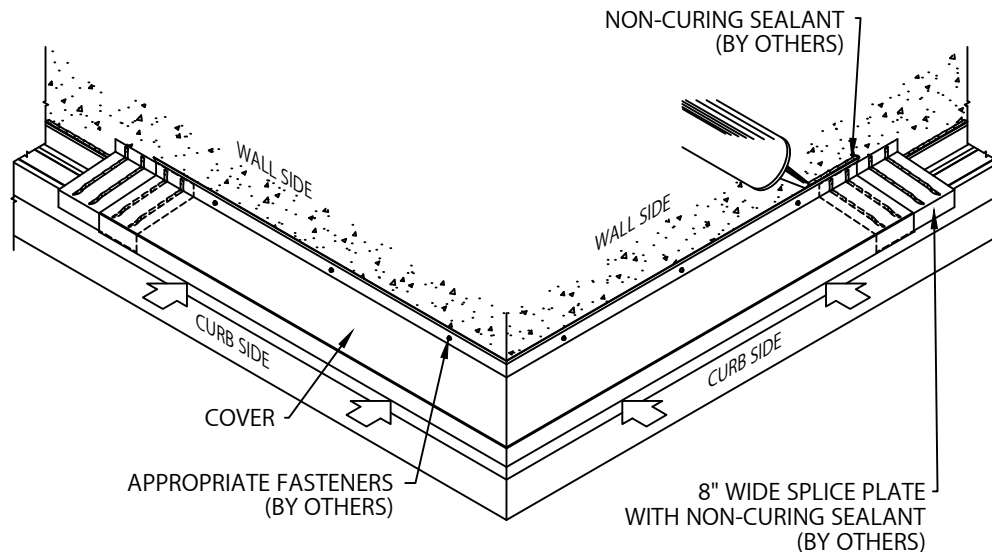

## 6. Miter Cover

Locate splice plates, apply non-curing sealant (by others) as shown and place into each end of miter cover. Install cover miter assembly straight onto miter cleat. Fasten the cover to the wall 12" O.C. through pre-slotted holes using appropriate fasteners (not provided). Apply non-curing sealant (by others) in trough at top of cover as shown.

**DO NOT OVERDRIVE THE SCREWS INTO THE CLEAT SO THAT THE SCREWS DO NOT RESTRICT MOVEMENT.**

## 7. Endcaps

Follow steps 1 and 2 installing condensate seal and rails. Loosely lay miter cleat in place over the expansion joint curb. Position the cleat so that the vertical flange is against wall. The cleat should extend beyond the curb. Secure the cleat with fasteners and shouldered washers provided through the slots of continuous cleat into the wood curb and fasteners with washers through slots into wall. The washers are to be placed extruded side down approximately slot center on the wall and center of the curb. Apply non-curing sealant (by others) to the top lip of surface mount continuous rail.

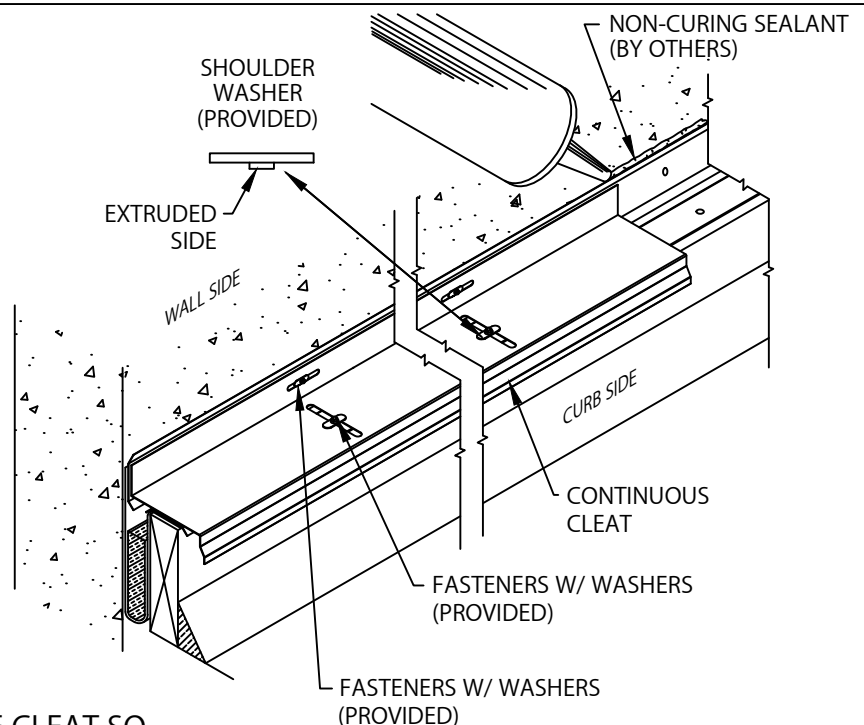

**DO NOT OVERDRIVE THE SCREWS INTO THE CLEAT SO THAT THE SCREWS DO NOT RESTRICT MOVEMENT.**

# PERMASPAN RW EXPANSION JOINT

ROOF TO WALL VERSION

INSTALLATION INSTRUCTIONS

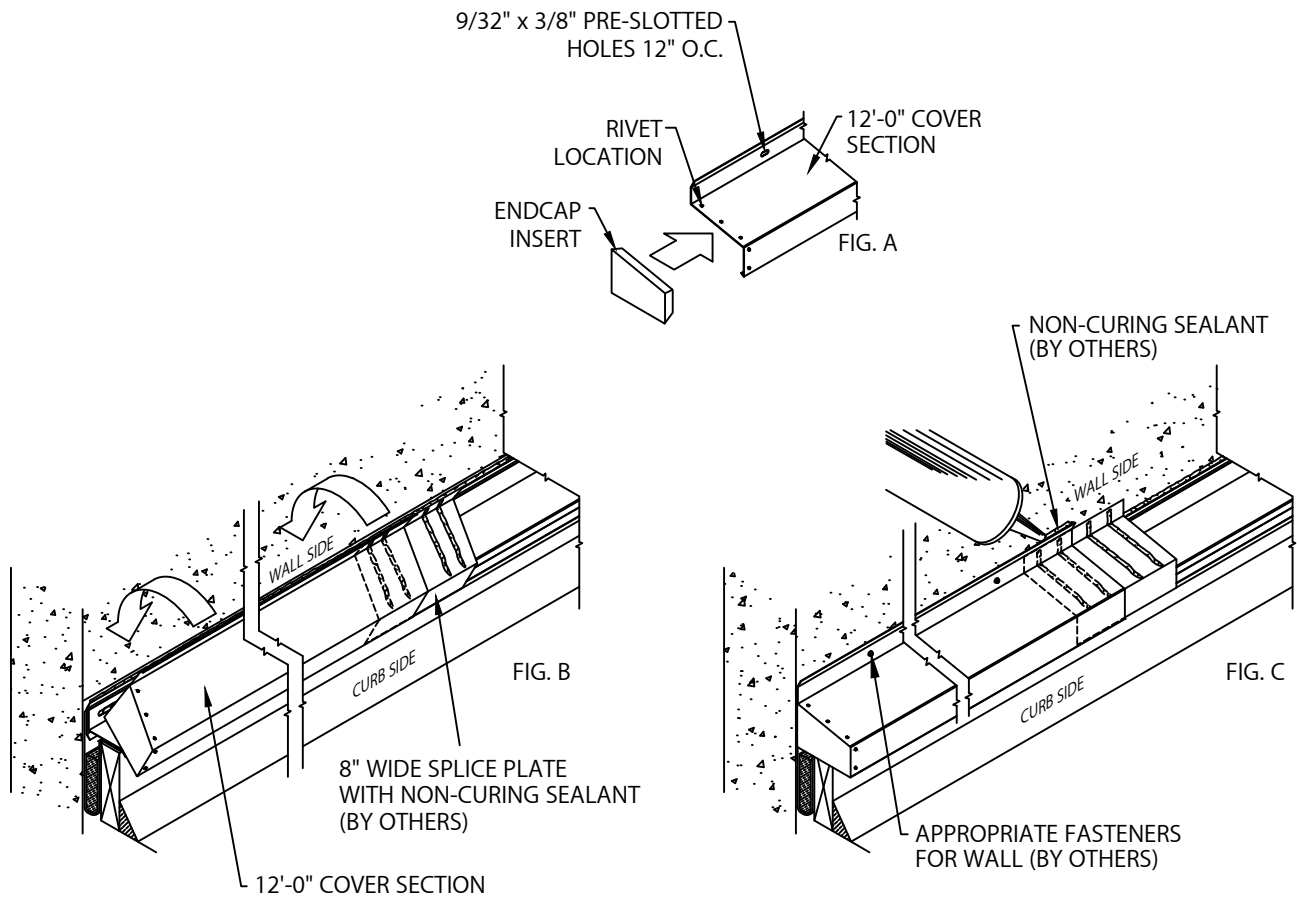

## 8. Endcap Inserts

Locate splice plate, apply non-curing sealant as shown and place into 12'-0" cover section (Fig. B). Place endcap insert into 12'-0" cover section

(Fig. A). Pop rivet (not provided) insert into place and seal tight using non-curing sealant on inside of cover along seams. Hook cover section on the curb side of the continuous cleat and rotate until the cover rests on the wall (Fig. B). Fasten to wall through pre-slotted holes 12" O.C. using appropriate fasteners (by others) for substrate. Apply non-curing sealant (by others) to cover as shown (Fig. C).

NOTE: Remove protective film immediately.

# PERMASPAN RW EXPANSION JOINT

ROOF TO WALL VERSION

## INSTALLATION INSTRUCTIONS

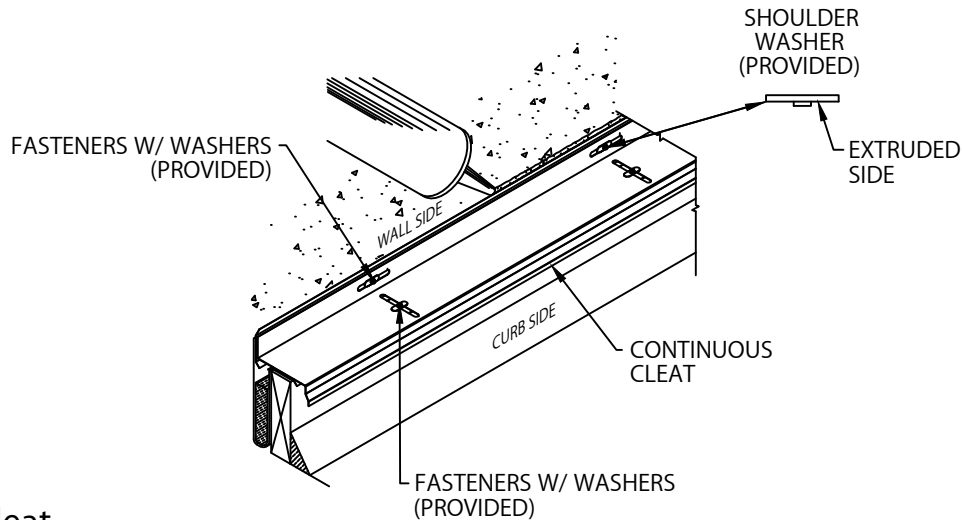

### 9. Continuous Cleat

Follow steps 1 and 2 installing condensate seal and rails. Starting at the ends, loosely lay continuous cleat in place over the expansion joint curb. Cut cover lengths as needed to cover entire run on the expansion joint. Position the cleat so that the vertical flange is against the wall. The cleat should extend beyond the curb. Secure the cleat with fasteners and shouldered washers provided through the slots of continuous cleat into the wood curb and fasteners with washers through slots into wall. The washers are to be placed extruded side down approximately slot center on the wall and center of the curb. Apply non-curing sealant (by others) to the top lip of surface mount continuous rail.

**DO NOT OVERDRIVE THE SCREWS INTO THE CLEAT SO THAT THE SCREWS DO NOT RESTRICT MOVEMENT.**

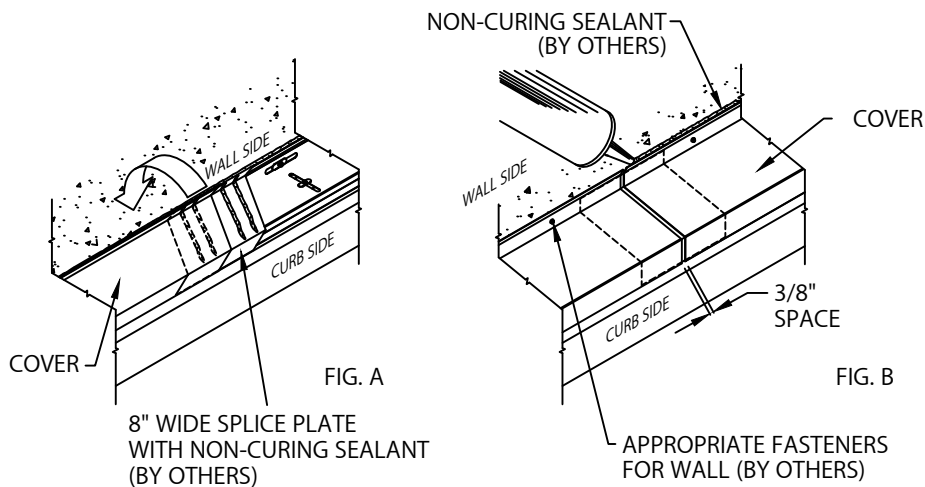

### 10. Expansion Joint Cover

Locate splice plate, apply non-curing sealant (by others) as shown and place into 12'-0" cover section. Hook cover section on the curb side of the continuous cleat and rotate until the cover rests on the wall (Fig. A). Fasten to wall through pre-slotted holes 12" O.C. using appropriate fasteners (by others) for substrate and apply non-curing sealant to cover as shown (Fig. B). Continue installing cover with 3/8" space at splice joints to allow for thermal expansion (Fig. B). Field cut where necessary using a fine tooth hacksaw or snips.

NOTE: Remove protective film immediately.

# PERMASPAN RW EXPANSION JOINT

ROOF TO WALL VERSION

INSTALLATION INSTRUCTIONS

## TYPICAL INSTALLATION

