

TERMINEDGE EX FASCIA

FULLY ADHERED OR MECHANICALLY ATTACHED SINGLE-PLY VERSION

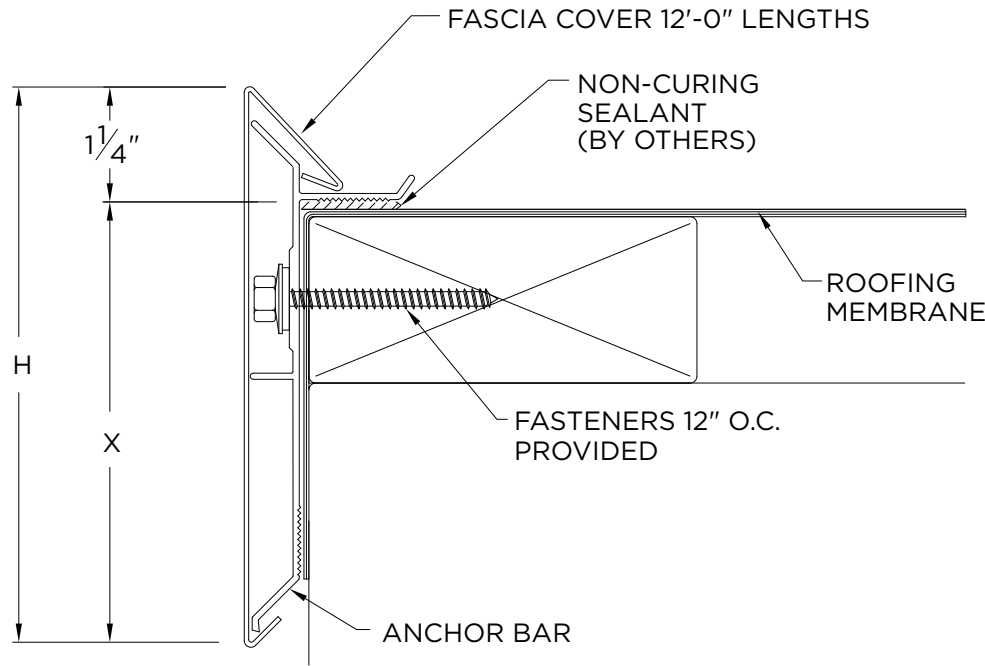

NOTES

- For non-90 miters, see separate print approval
- Product should be installed per provided installation instructions
- ANSI/SPRI/FM 4435/ES-1 Test Pressure up to 275 psf.

APPROVALS



ANSI/SPRI/FM 4435/ES-1
Test Pressures listed in notes

PROJECT INFO

Project Name: _____

Architect: _____

Roofing Contractor: _____

Project Type:

By selecting this box you have verified and confirmed that dimensions, sizes, and quantities are correct. All products will be installed in strict accordance with printed instructions.

Date: _____

Hickman Edge Systems

4 Commerce Way
Arden, NC 28704
Phone: 828-676-1700
www.hickmanedgesystems.com

SHT# 1 of 1

DATE: 10/18/21

DRN BY: JJC

CKD BY: MM

DWG #: 64010-36604

REV: A

DIMENSIONS

PRODUCT ID. NO.	H DIM	X DIM	NAILER COVERAGE
<input type="checkbox"/> AF-40	4"	2 3/4"	1 NAILER
<input type="checkbox"/> AF-55	5 1/2"	4 1/4"	2 NAILERS
<input type="checkbox"/> AF-70	7"	5 3/4"	3 NAILERS
<input type="checkbox"/> AF-85	8 1/2"	7 1/4"	4 NAILERS

MATERIAL

- 24 Ga. Galv. Steel Color: _____
- 22 Ga. Galv. Steel Finish: _____
- .040" Aluminum
- Substrate:** Wood
If substrate is not given, wood fasteners will be provided. Masonry
 Metal
- OTHER: _____

QUANTITIES

_____ Lineal Feet (12'-0" Lengths)

_____ Outside Miter (90°)

_____ Inside Miter (90°)

_____ Right Endcaps

_____ Left Endcaps

_____ Right Endwall Flashing

_____ Left Endwall Flashing

_____ Overflow Scupper

Style A

Style B

_____ Spillout Scupper

Style A

Style B

_____ Downspout Scupper

Style A Style B

Size _____ x _____

Style A=Tapered 1.5" Drop | Style B=Flat