



PO Box 1289, Carlisle, PA, 17013

Phone: (800) 992-7663

www.versico.com

INSTALLATION INSTRUCTION FOR VERSITRIM 200 COPING

APPROVALS*

ANSI/SPRI/FM 4435/ES-1



*MAXIMUM TESTED DIMENSIONS: INSIDE FACE: 4" | OUTSIDE FACE: 6" | WALL WIDTH: 16"

DATE: 03/03/23 | DRN BY: MLM | CKD BY: MM | DWG #: 18111-40385 | REV. B

TABLE OF CONTENTS

Overview of Coping Versions	Page 3
Substrate and Fastener Information	Page 4
Anchor Clip Spacing	Page 4
Standard Installation Steps (Including Standard Accessories)	Page 5-7
Radius Coping Installation Steps	Page 7
Arched Coping Installation Steps	Page 8

VERSITRIM 200 COPING

COPING VERSIONS

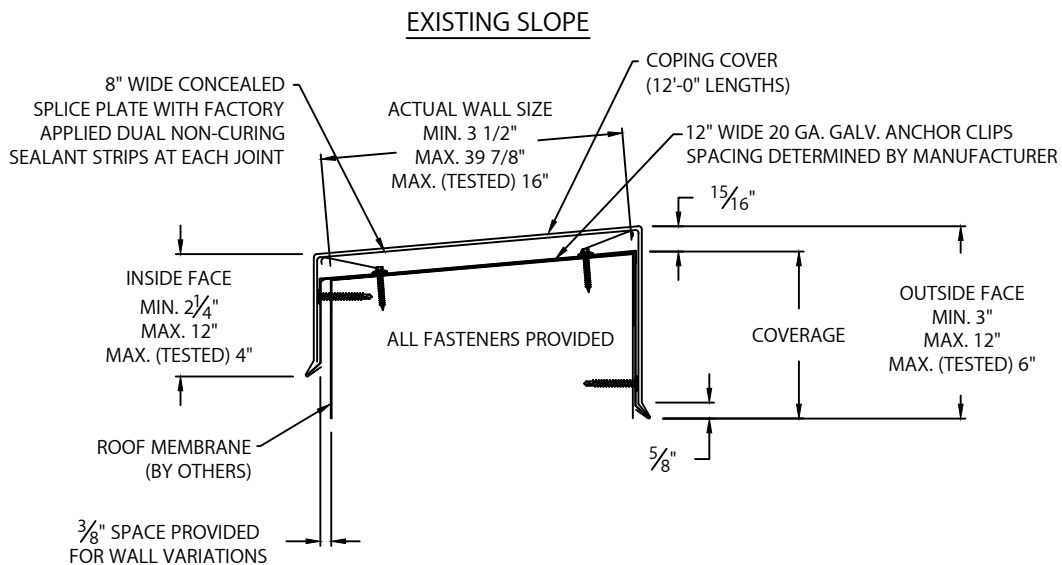
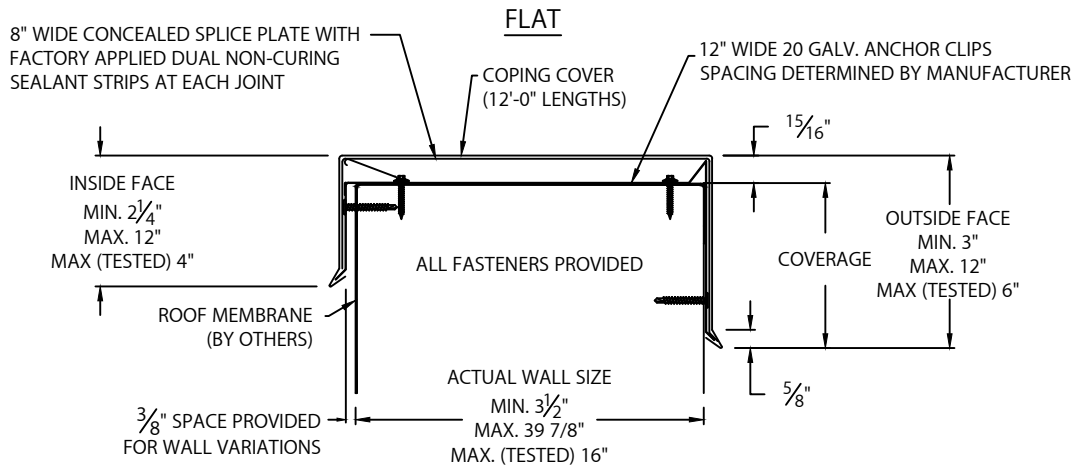
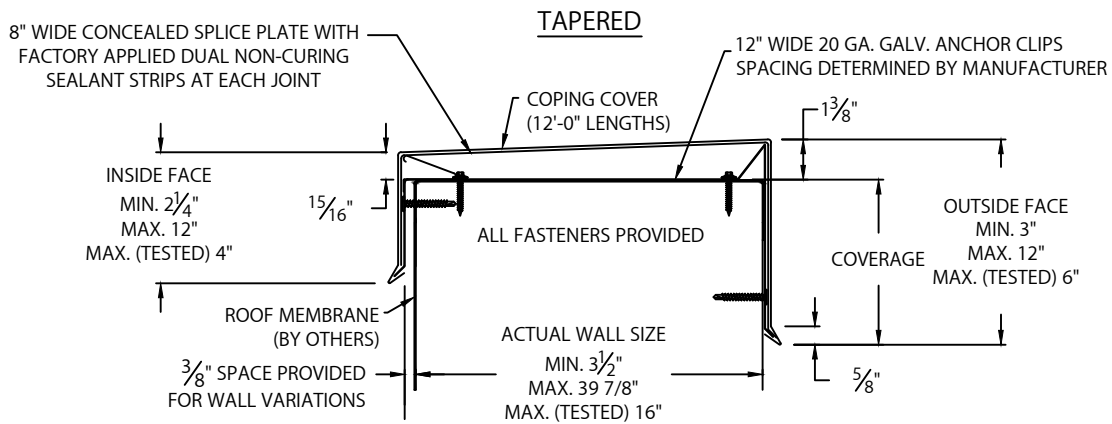

VERSITRIM 200 COPING

FASTENERS AND ANCHOR CLIP INFORMATION

COPING SUBSTRATE AND FASTENERS

THIS COPING CAN BE INSTALLED ON THE FOLLOWING SUBSTRATE USING THE FASTENERS PROVIDED BY THE MANUFACTURER .
TYPICAL INSTALLATION ON WOOD SUBSTRATE. (TAPERED VERSION SHOWN)

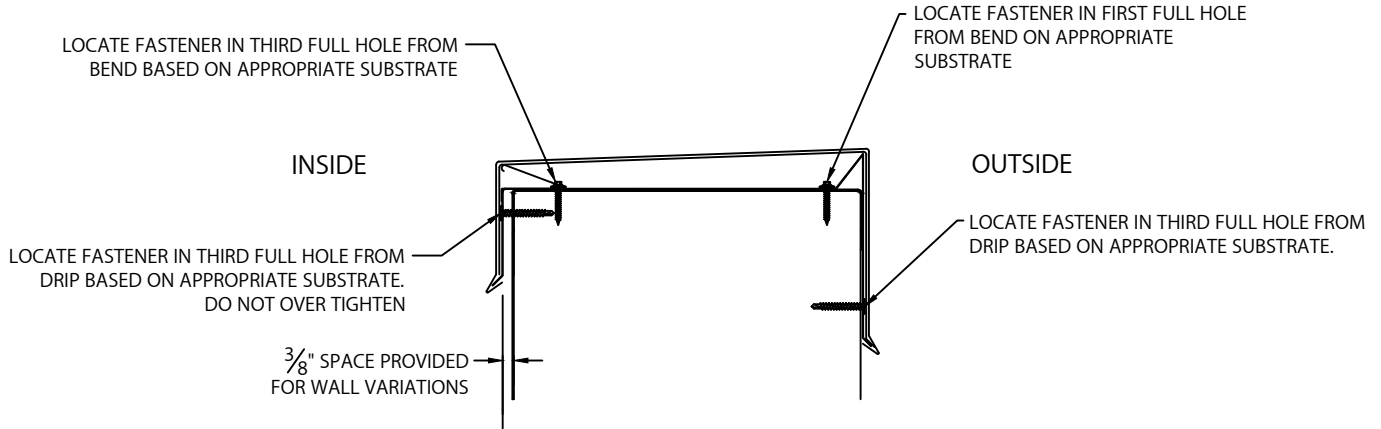

SUBSTRATE	TOP FASTENERS	FACE FASTENERS
WOOD	#10 X 1-1/2" STAINLESS STEEL SCREW	#14 X 1-1/2" PROFILER
MASONRY	1/4" X 1-1/4" TAPCON	#14 X 1-1/2" PROFILER
METAL	#12-14 X 1" TEK3	#14 X 1-1/2" PROFILER

NOTE: ALTERNATIVE OR UNIVERSAL FASTENERS MAY BE PROVIDED AS A SUBSTITUTE FOR THE FASTENERS LISTED BASED ON AVAILABILITY. ANY SUBSTITUTE FASTENER PROVIDED WILL BE OF EQUAL OR GREATER EQUIVALENCY.

COPING ANCHOR CLIPS AND SPACING

ANCHOR CLIP SPACING IS DETERMINED BY THE MANUFACTURER BASED ON WALL SIZE.

ANCHOR CLIP SPACING FOR STRAIGHT LENGTHS

WALL SIZE	ANCHOR CLIP SPACING
0" THRU 12"	4' - 0" O.C.
12 - 1/16" THRU 24"	3' - 0" O.C.
24-1/16" THRU 39 7/8"	2' - 0" O.C.

NOTE: ALL PROJECTS IN FLORIDA WILL USE 3'-0" O.C. SPACING

ANCHOR CLIP DETAIL FOR WALLS GREATER THAN 14"

NOTE: ALL RADIUS COPING WILL HAVE DOUBLE SPRING ANCHOR CLIPS

TAPERED AND FLAT

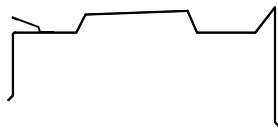

EXISTING SLOPE

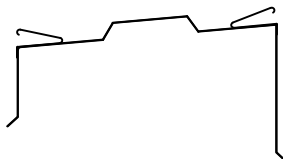

ANCHOR CLIP AND SPLICE PLATE INFORMATION FOR RADIUS COPING

WALL WIDTH	SPLICE PLATE WIDTH	ANCHOR CLIP WIDTH	ANCHOR CLIP SPACING

VERSITRIM 200 COPING

INSTALLATION INSTRUCTIONS

IMPORTANT: Prior to installation, read instructions carefully.

NOTE: Position roof membrane on top of the wall covering the treated wood nailer(s) or substrate completely. Allow 1/2" minimum excess membrane beyond nailer where applicable.

CAUTION: INSTALL ACCESSORIES FIRST!

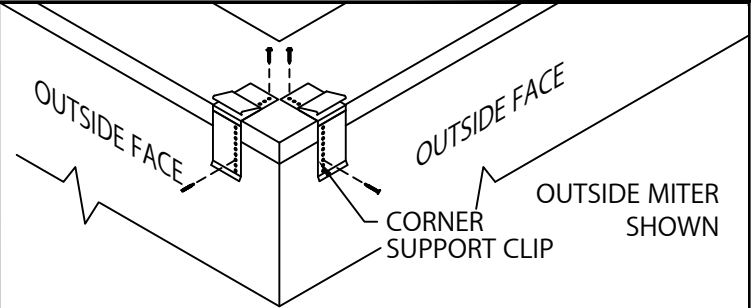

STEP 1 - CORNER SUPPORT CLIPS

LOCATE AND FASTEN GALVANIZED CORNER SUPPORT CLIPS TO THE WALL.

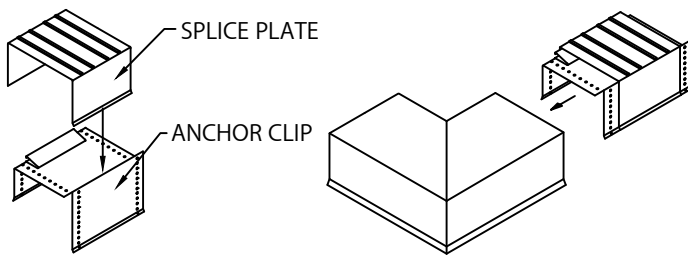

STEP 2 - MITER SPLICE PLATES & ANCHOR CLIPS

POSITION THE SPLICE PLATE IN THE CENTER OF THE ANCHOR CLIP. INSTALL THE SPLICE PLATE AND ANCHOR CLIP ASSEMBLY INTO EACH END OF THE CORNER AS SHOWN

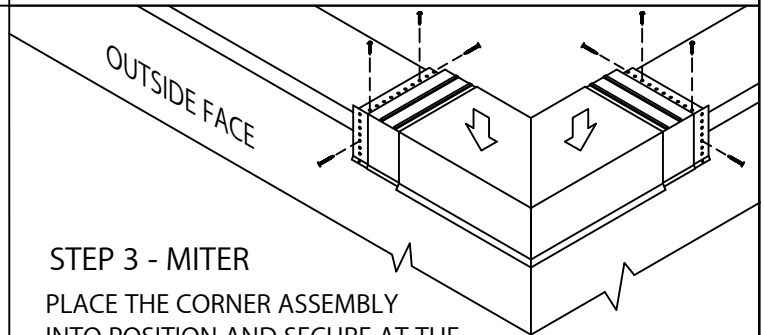

STEP 3 - MITER

PLACE THE CORNER ASSEMBLY INTO POSITION AND SECURE AT THE EXPOSED EDGE OF THE ANCHOR CLIPS AS PER COPING SUBSTRATE AND FASTENERS DETAIL ON PAGE 4.

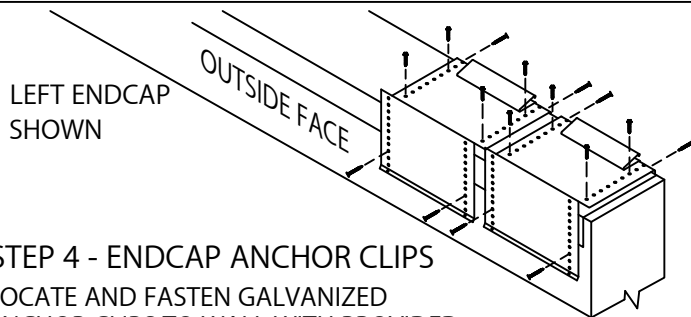

STEP 4 - ENDCAP ANCHOR CLIPS

LOCATE AND FASTEN GALVANIZED ANCHOR CLIPS TO WALL WITH PROVIDED FASTENERS. SEE COPING SUBSTRATE AND FASTENERS DETAIL ON PAGE 4.

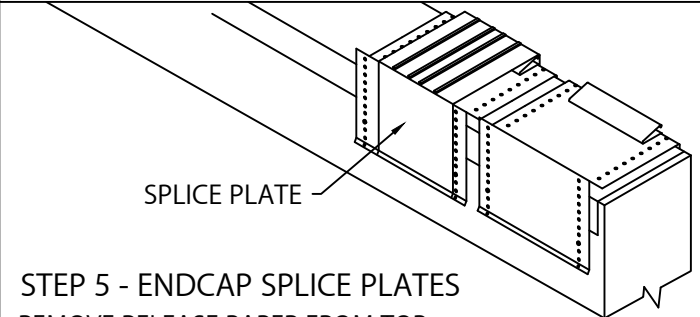

STEP 5 - ENDCAP SPLICE PLATES

REMOVE RELEASE PAPER FROM TOP OF FACTORY APPLIED SEALANT STRIPS. PLACE SPLICE PLATE ONTO SECOND ANCHOR CLIP AS SHOWN.

STEP 6 - ENDCAP

HOOK OUTSIDE FACE OF THE ENDCAP OVER THE ANCHOR CLIPS AND ROTATE INTO PLACE. ENGAGE REAR LEG ONTO ANCHOR CLIPS BY PRESSING DOWNWARD UNTIL SNAP LOCK OCCURS.

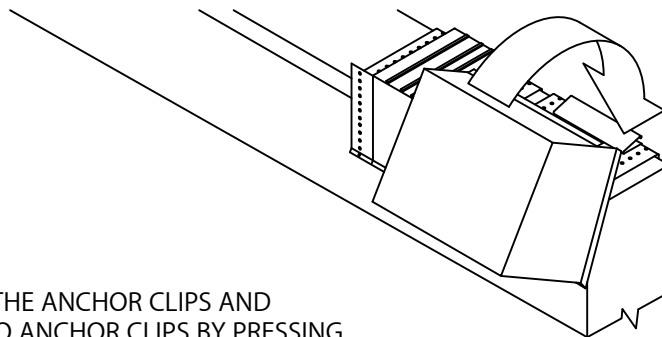

VERSITRIM 200 COPING

INSTALLATION INSTRUCTIONS

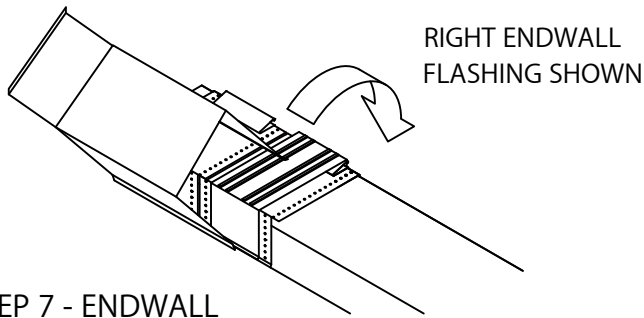

STEP 7 - ENDWALL

ENDWALL FLASHING COPING VERSION STEPS 7 - 8

HOOK OUTSIDE FACE OF ENDWALL OVER THE ANCHOR CLIPS AND ROTATE INTO PLACE. ENGAGE REAR LEG ONTO ANCHOR CLIPS BY PRESSING DOWNWARD UNTIL SNAP LOCK OCCURS.

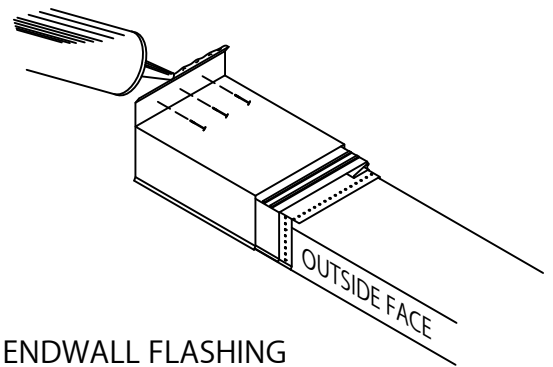

STEP 8 - ENDWALL FLASHING

FASTEN TO WALL USING APPROPRIATE FASTENERS AS SHOWN. APPLY NON-CURING SEALANT (BY OTHERS) TO CAULK CUP ATOP 3" FLANGE.

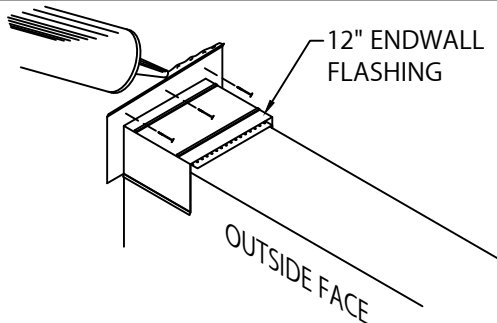

STEP 9 - ENDWALL FLASHING

ENDWALL FLASHING SPLICE VERSION STEPS 9 - 10

PLACE ENDWALL FLASHING ON TOP OF ANCHOR CLIP. REMOVE RELEASE PAPER FROM SPLICE PLATE SEALANT STRIPS. FASTEN TO WALL USING APPROPRIATE FASTENERS AS SHOWN. APPLY NON-CURING SEALANT (BY OTHERS) TO CAULK CUP ATOP 3" FLANGE.

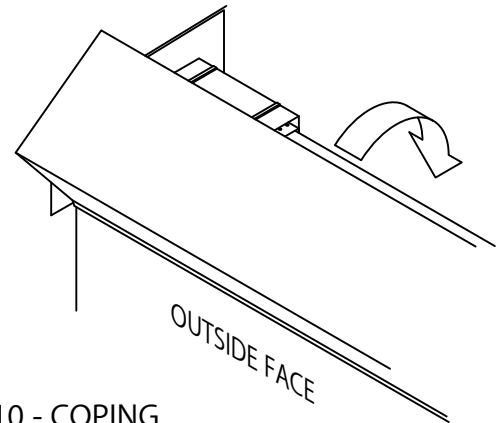

STEP 10 - COPING

HOOK OUTSIDE FACE OF COPING OVER THE ANCHOR CLIP/ENDWALL FLASHING AND ROTATE INTO PLACE. ENGAGE REAR LEG ONTO ANCHOR CLIP BY PRESSING DOWNWARD UNTIL SNAP LOCK OCCURS.

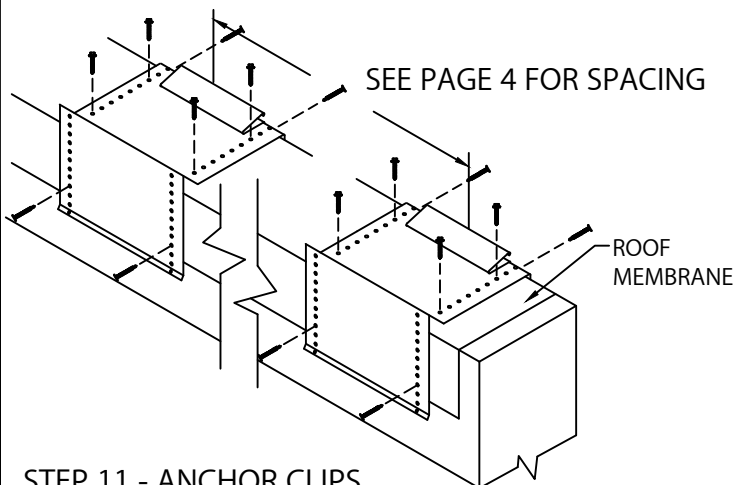

STEP 11 - ANCHOR CLIPS

LOCATE AND FASTEN GALVANIZED ANCHOR CLIPS TO WALL AT CENTERS WITH PROVIDED FASTENERS FOR SUBSTRATE SEE COPING ANCHOR CLIPS AND SPACING ON PAGE 4.

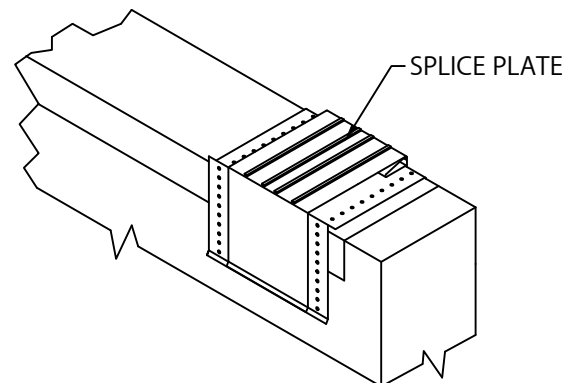

STEP 15 - SPLICE PLATES

PLACE SPLICE PLATE ONTO ANCHOR CLIPS AT SPLICE JOINTS.
NOTE: REMOVE RELEASE PAPER FROM SEALANT STRIPS.

VERSITRIM 200 COPING

INSTALLATION INSTRUCTIONS

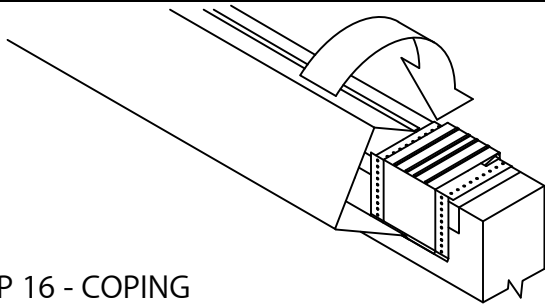

STEP 16 - COPING

HOOK OUTSIDE FACE OF COPING OVER THE ANCHOR CLIPS AND ROTATE INTO PLACE. ENGAGE REAR LEG ONTO ANCHOR CLIPS BY PRESSING DOWNWARD UNTIL SNAP LOCK OCCURS.

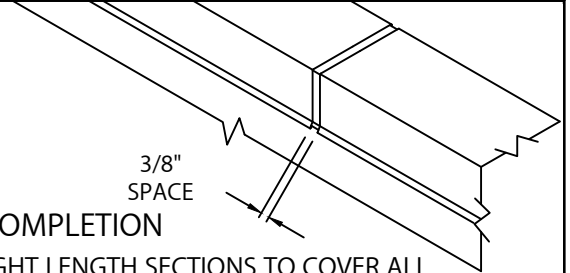

STEP 17 - COMPLETION

USING STRAIGHT LENGTH SECTIONS TO COVER ALL EXPOSED CLIPS / SPLICES, CUT TO LENGTH AS NEEDED USING A FINE TOOTH HACKSAW, SNIIPS, OR CUT-OFF WHEEL LEAVING A CLEAN EDGE. BE SURE TO LEAVE A 3/8" SPACE AT EACH JOINT.

NOTE: REMOVE PROTECTIVE FILM IMMEDIATELY.

VERSITRIM 200 RADIUS COPING INSTRUCTIONS

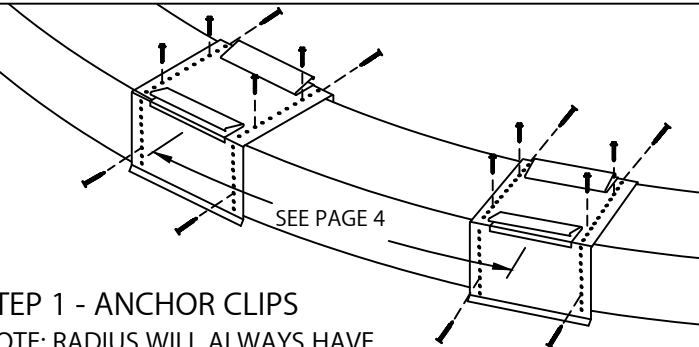

STEP 1 - ANCHOR CLIPS

NOTE: RADIUS WILL ALWAYS HAVE DOUBLE SPRING ANCHOR CLIPS. WIDTH WILL BE DETERMINED BY RADIUS SIZE AND MATERIAL. LOCATE AND FASTEN ANCHOR CLIPS WITH PROVIDED FASTENERS FOR SUBSTRATE (SEE PAGE 4). FOR ANCHOR CLIP SPACING (SEE PAGE 4).

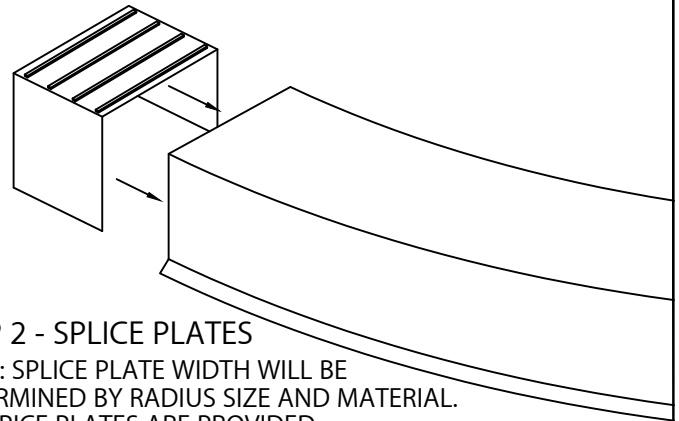

STEP 2 - SPLICE PLATES

NOTE: SPLICE PLATE WIDTH WILL BE DETERMINED BY RADIUS SIZE AND MATERIAL. ALL SPICE PLATES ARE PROVIDED. REMOVE RELEASE PAPER FROM LEFT TWO SEALANT STRIPS. INSERT SPLICE PLATE INTO THE RIGHT END OF RADIUS SECTION.

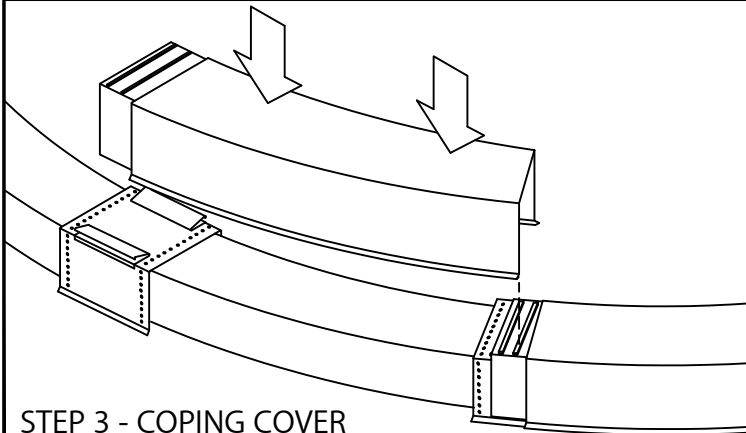

STEP 3 - COPING COVER

NOTE: 4'-0" O.C. SHOWN
REMOVE RELEASE PAPER FROM RIGHT TWO FACTORY APPLIED SEALANT STRIPS ON THE SPLICE PLATE IN THE COPING SECTION. INSTALL RADIUS COPING SECTIONS FROM LEFT TO RIGHT. PLACE COPING INTO POSITION AND PRESS DOWNWARD UNTIL SNAP-LOCK OCCURS.

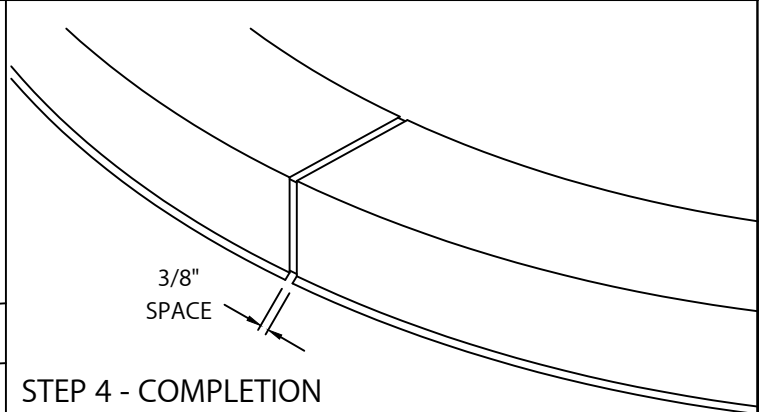

STEP 4 - COMPLETION

USING RADIUS SECTIONS TO COVER ALL EXPOSED CLIPS / SPLICES, CUT TO LENGTH AS NEEDED USING A FINE TOOTH HACKSAW, SNIPS, OR CUT-OFF WHEEL LEAVING A CLEAN EDGE. BE SURE TO LEAVE A 3/8" SPACE AT EACH JOINT.

NOTE: REMOVE PROTECTIVE FILM IMMEDIATELY.



Customer Service
800-558-2162

DATE: 06/01/23
DRN BY: MLM
CKD BY: MM

SHT.# 7 OF 8

DWG# 18111-40385

B

ARCHED COPING

INSTALLATION INSTRUCTIONS

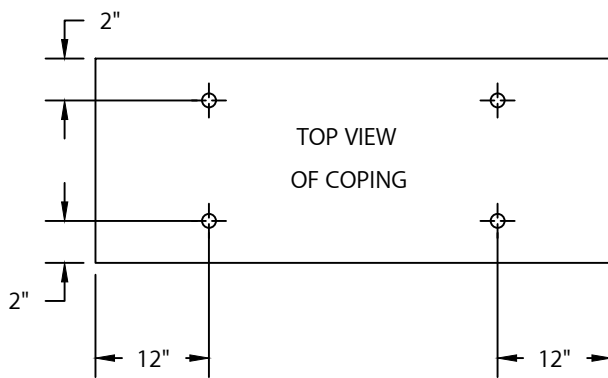
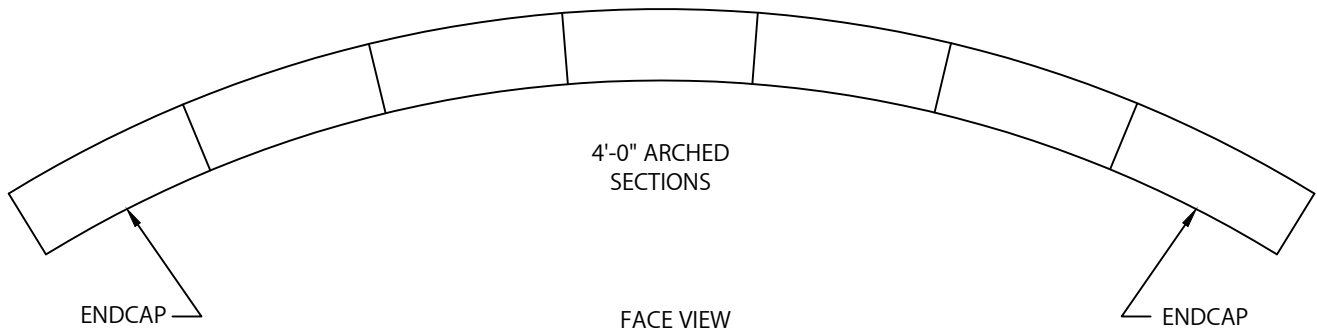

STEP 1 - ENDCAPS

NOTE: FASTENERS ARE NOT PROVIDED FOR ARCHED COPING.
LOCATE APPROPRIATE FASTENERS AND SECURE INTO TOP OF ENDCAP AS SHOWN ABOVE.

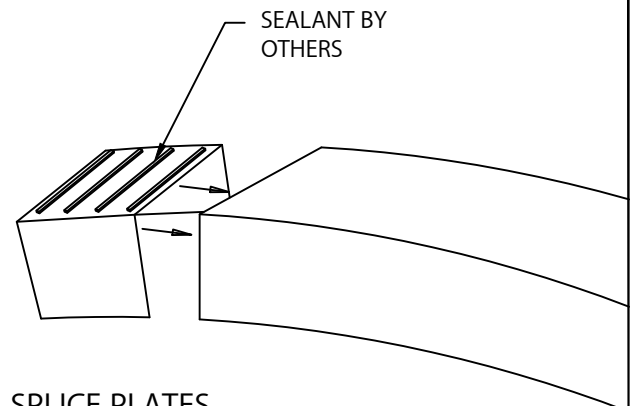

STEP 2 - SPLICE PLATES

INSTALL ENDCAPS FIRST BY INSERTING A SPLICE PLATE UNDER ENDCAP WITH SEALANT. THEN CONTINUE INSTALLATION BY LOCATING AND SECURING ENDCAPS WITH APPROPRIATE FASTENERS PROVIDED INTO PRE-PUNCHED CONTINUE INSTALLATION WITH ARCHED COVERS. (USE SINGLE ISOMETRIC IMAGE WITH PRE-PUNCHED HOLES)

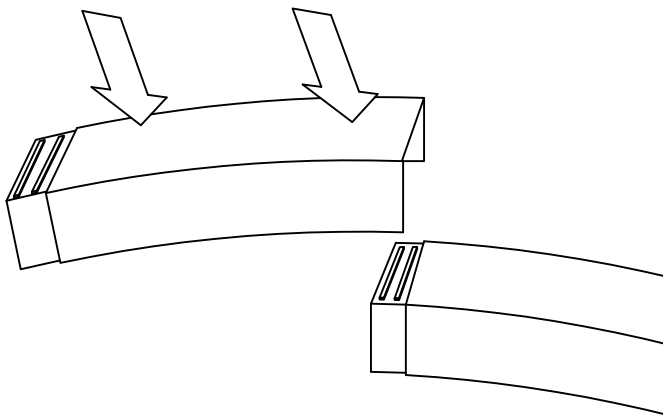

STEP 3 - COPING COVER

PLACE COPING INTO POSITION ALLOWING 3/8" SPACE AT SPLICE JOINT. FASTEN THROUGH TOP OF COPING AS SHOWN IN STEP #1

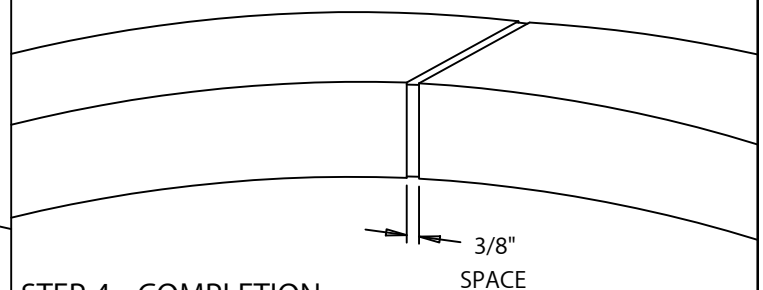

STEP 4 - COMPLETION

NOTE: REMOVE PROTECTIVE FILM IMMEDIATELY.
USING ARCHED SECTIONS TO COVER WALL CONDITIONS, CUT TO LENGTH AS NEEDED USING A FINE TOOTH HACKSAW, SNIPS, OR CUT-OFF WHEEL LEAVING A CLEAN EDGE.