

Installation Guide for UNA-Edge OM Extender

Firestone

Firestone Building Products

200 4th Avenue South

Nashville, TN 37201

Tel.: (800) 428-4442

Installation Guide for UNA-Edge OM Extender

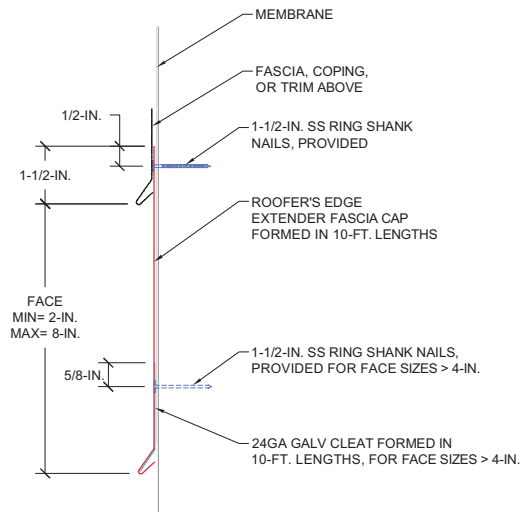

FOR MASONRY APPLICATIONS, PLEASE CONTACT US.

CONTACT US FOR APPROPRIATE RECOMMENDATIONS NEEDED TO MEET/EXCEED ANSI/SPRI/FM4435/ES-1 DESIGN CRITERIA

NOTES:

- #1 - Isolate all metal parts from ACQ treated wood or other galvanically incompatible material with appropriate membrane material.
- #2 - Appliance attachments, such as lightning rods, signs, or antennae that penetrate the edge system, induce a galvanic reaction, or otherwise compromise the effectiveness of the roof edge system, shall be eliminated or isolated to prevent problems per ANSI/SPRI/FM4435/ES-1. Lightning protection systems for example must not be directly affixed to the product provided.

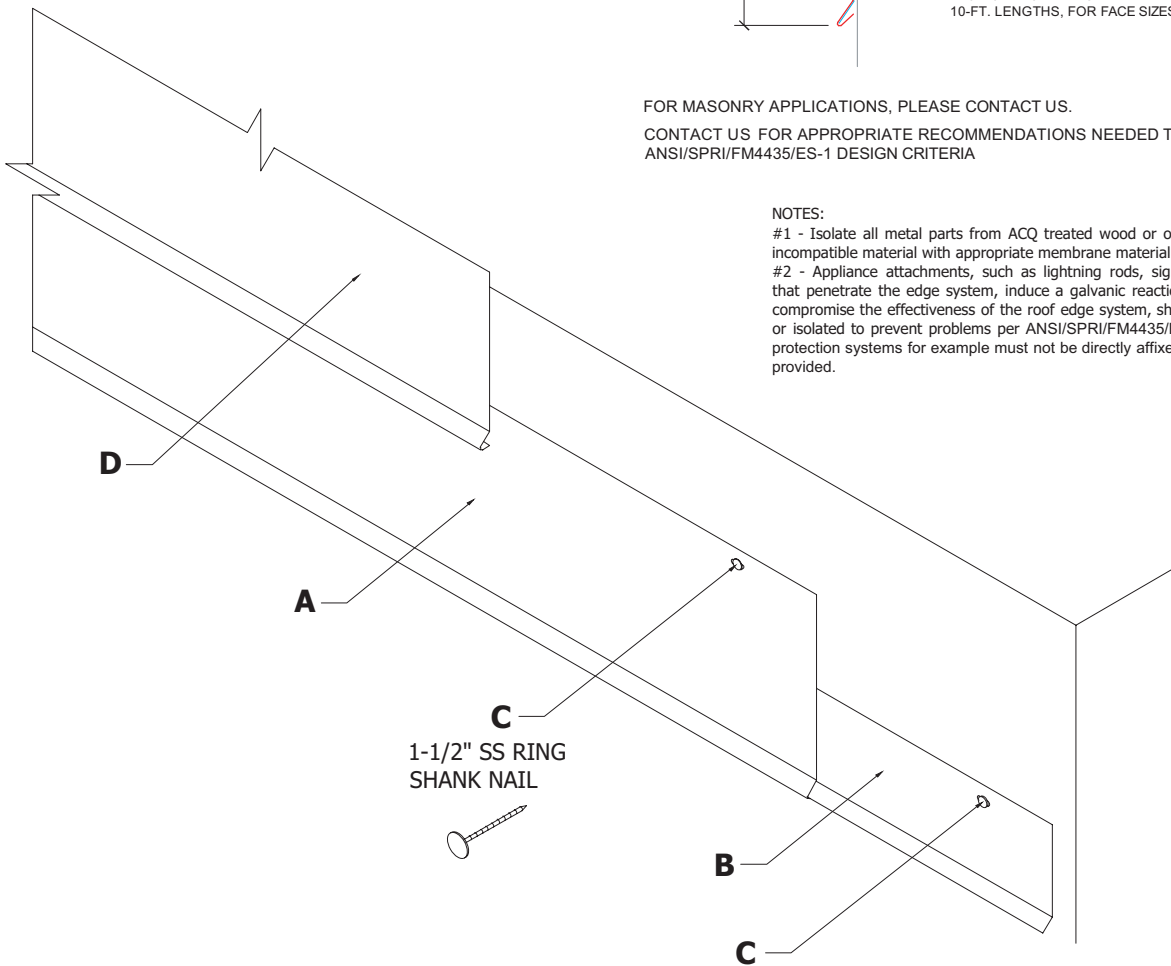

A. Fascia Cover

10'-0" Lengths

B. Galvanized Anchor Cleat

for face size > 4"

10'-0" Lengths

C. 1-1/2" SS Ring Shank Nail

at 12" o.c. (6" from ends)

(Included & Required)

D. Fascia, Coping, or Trim above

(Product may vary)

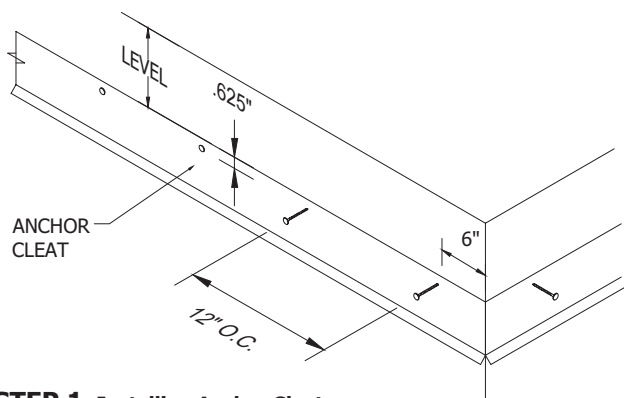

**STEP 1: Installing Anchor Cleat
(not required for face size ≤ 4")**

Place the top edge of the anchor cleat level on the wall face and press cleats securely in position and nail through cleat using 1-1/2" ss ring shank nails provided at the locations shown above and at 12" O.C. For miter application, fit into corner as required to maintain a continuous anchor cleat line. Then nail at a max. of 6" in each direction from the corner or closer at special conditions.

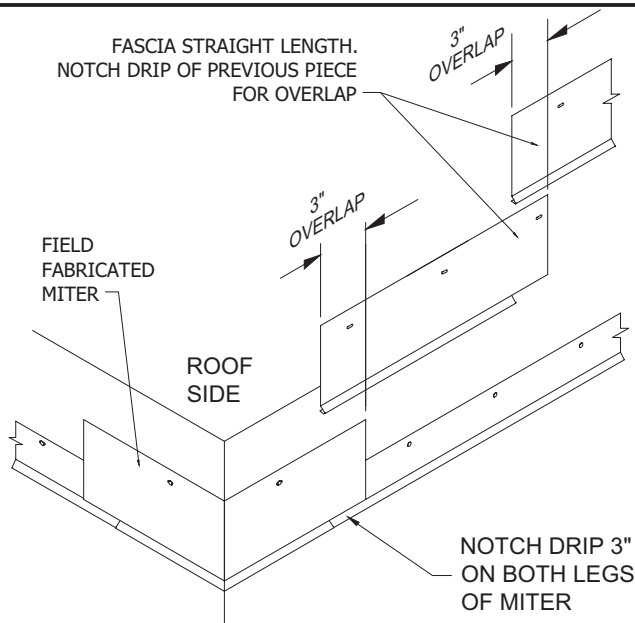
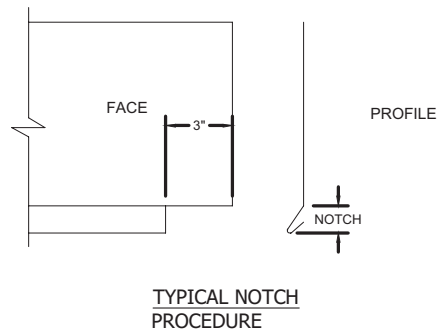

STEP 2: Installing Fascia Straight Lengths

Notch each drip of field fabricated miter 3". Then notch the drip of following 10'-0" piece as shown above. Install the fascia by hooking the drip of the fascia onto the kick out of the cleat and rotate back to the wall. Fasten with 1-1/2" SS ring shank nails provided in each pre-punched hole. Consider lengths of all straight pieces prior to cutting to avoid creating relatively short sections of fascia adjacent to full length sections.

Note: Notch the drip of the 1st pc. to allow overlapping of the next adjacent piece.

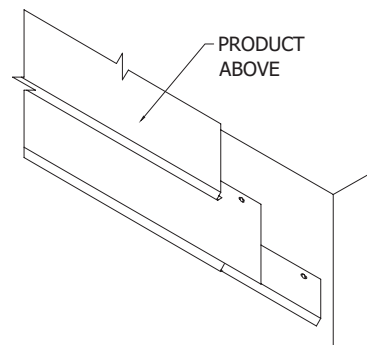

STEP 3: Installing Product Above

Install product above fascia per manufacturer's installation instructions.

Firestone

Firestone Building Products

Firestone Building Products

200 4th Avenue South

Nashville, TN 37201

Tel.: (800) 428-4442