



# PERMASNAP CONTINUOUS CLEAT RADIUS COPING

TO BE USED WITH CONTINUOUS CLEAT COPING, TAPERED VERSION - 2'-0" O.C.

## INSTALLATION INSTRUCTIONS

NOTE: Position roof membrane on top of the wall covering the treated wood nailer(s) or substrate completely. Allow 1/2" minimum excess membrane beyond nailer where applicable. NRCA Requirement. Membrane not shown for clarity.

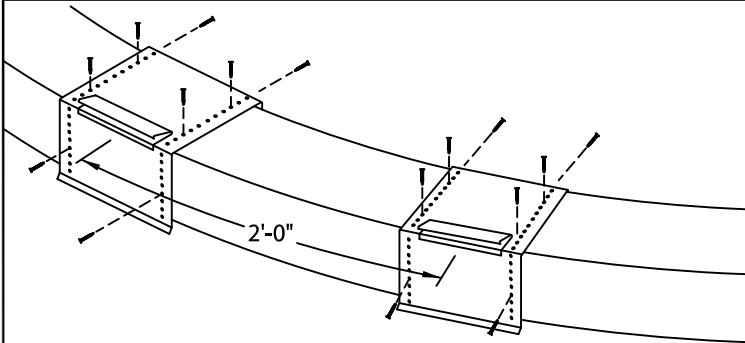

### STEP 1 - Anchor Clips

Locate and fasten anchor clips at 2'-0" O.C. with provided fasteners for substrate (see detail A).

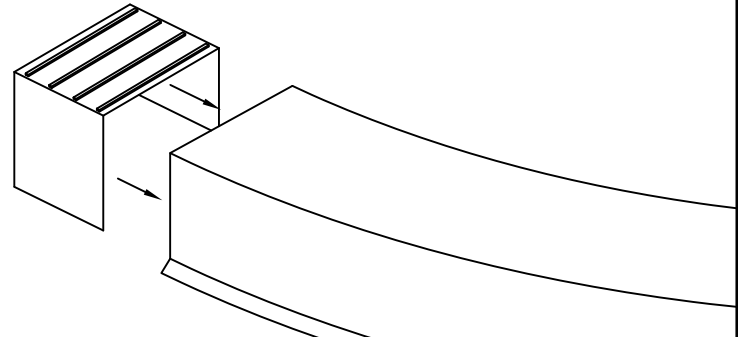

### STEP 2 - Splice Plates

Remove release paper from left two sealant strips. Insert splice plate into the right end of radius section.

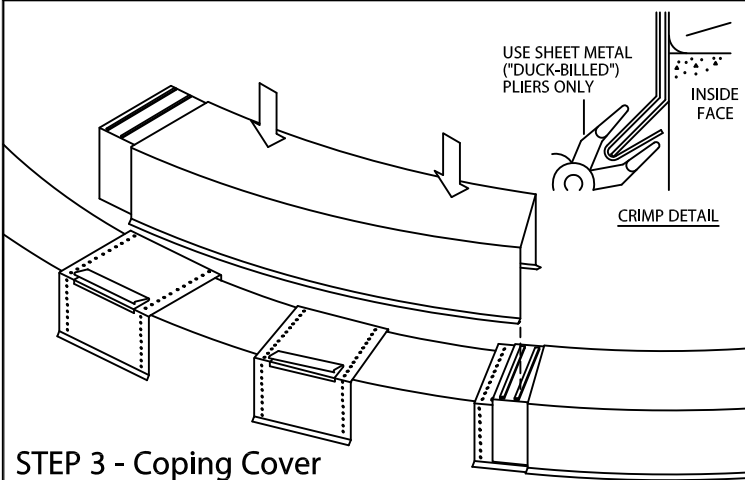

### STEP 3 - Coping Cover

Remove release paper from right two factory applied sealant strips on the splice plate in the coping section. Install 4'-0" radius coping sections from left to right. Place coping into position and press downward until snap-lock occurs. Field crimp inside drip at all anchor clips.

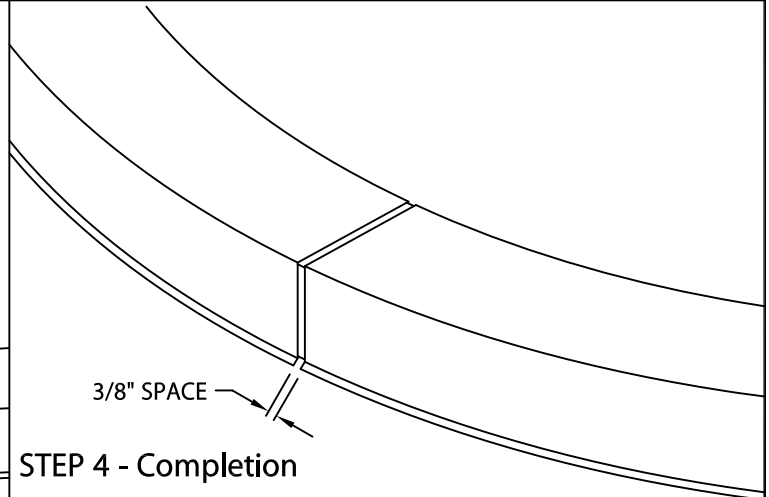

### STEP 4 - Completion

Continue installing coping with a 3/8" space at splice joints to allow for thermal expansion. Field cut where necessary using a fine tooth hacksaw or snips. NOTE: REMOVE PROTECTIVE FILM IMMEDIATELY.

### ANCHOR CLIP FASTENING-DETAIL A

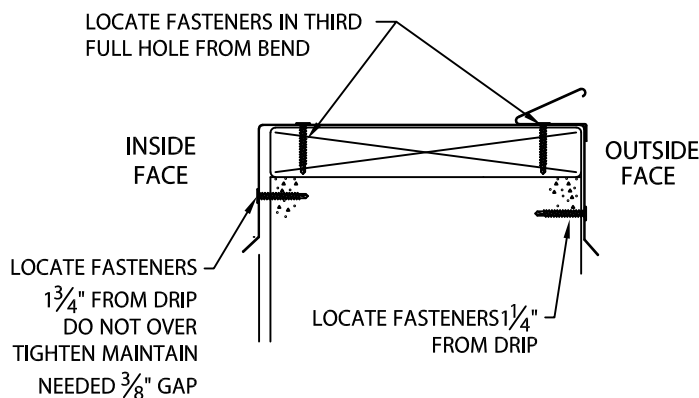

### TYPICAL COPING INSTALLATION

