

FLOW-THRU DRAIN BAR

NOTES

- Includes concealed splice plates at each joint that must be field caulked to prevent water entry
- Product should be installed per provided installation instructions

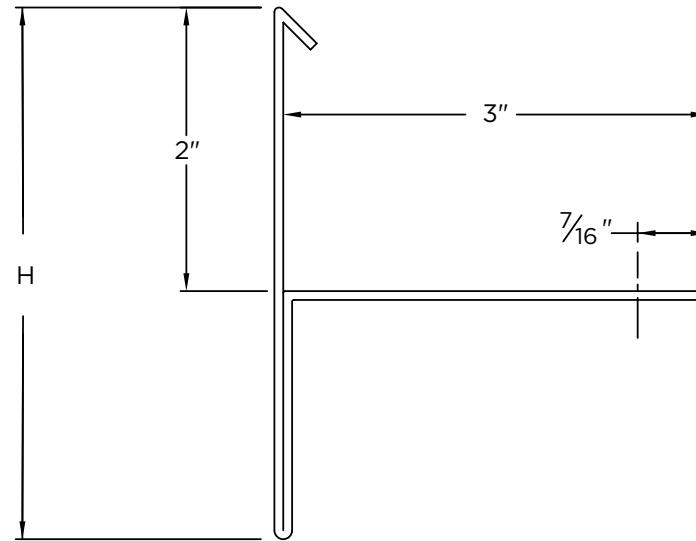
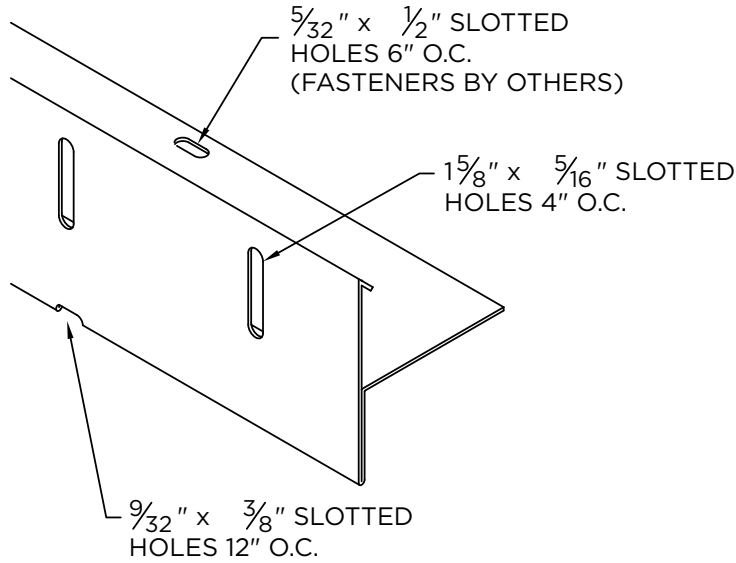

PROJECT INFO

Project Name: _____

Architect: _____

Roofing Contractor: _____

Project Type:

By selecting this box you have verified and confirmed that dimensions, sizes, and quantities are correct. All products will be installed in strict accordance with printed instructions.

Date: _____

Hickman Edge Systems
4 Commerce Way
Arden, NC 28704
Phone: 828-676-1700
www.hickmanedgesystems.com

SHT# 1 of 1

DATE: 02/07/ 22

DRN BY: JJC

CKD BY: MM

DWG #: 64016-37165

REV: A

DIMENSIONS

Face Height (H Dim)

3.75" (FT-375)

5" (FT-500)

MATERIAL

.040" Aluminum

.050" Aluminum

Color: _____

Finish: _____

QUANTITIES

_____ Lineal Feet (12'-0" Lengths)