

PERMASNAP DUAL CANTILEVER COPING

3'-0" O.C.

INSTALLATION INSTRUCTIONS

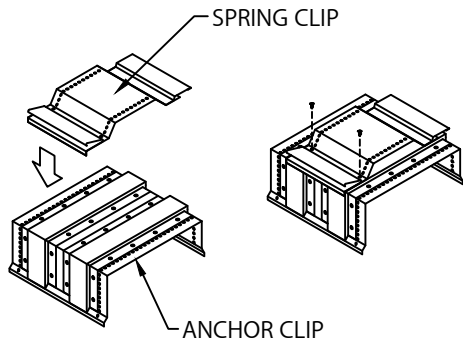

STEP 1 - SPRING CLIP / ANCHOR CLIP

POSITION THE SPRING CLIPS IN THE CENTER OF THE ANCHOR CLIPS AND SECURE INTO PLACE WITH PROVIDED FASTENERS (SEE DETAIL A).

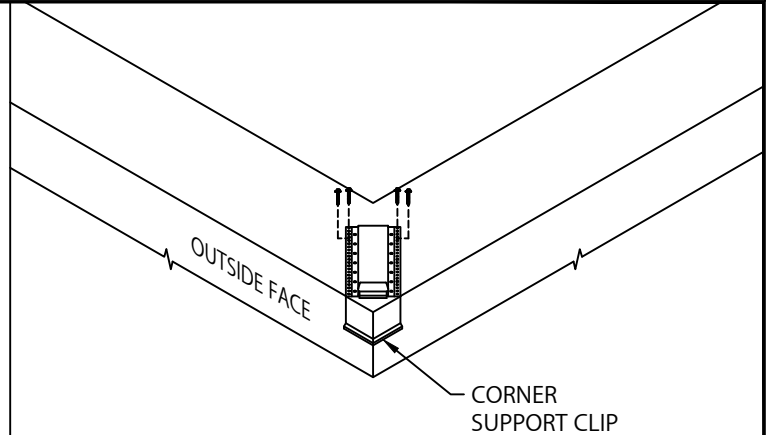

STEP 2 - CORNER SUPPORT CLIPS

LOCATE AND FASTEN ONE GALVANIZED CORNER SUPPORT CLIP TO THE WALL AS SHOWN USING FOUR FASTENERS (PROVIDED).

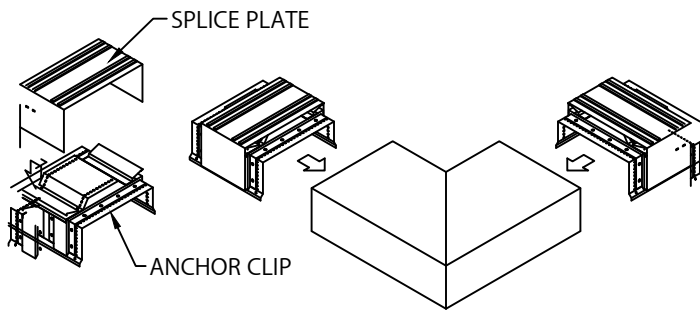

STEP 3 - MITER SPLICE PLATES & ANCHOR CLIPS

POSITION THE SPLICE PLATE IN THE CENTER OF THE ANCHOR CLIP. INSTALL THE SPLICE PLATE AND ANCHOR CLIP ASSEMBLY HALFWAY INTO EACH END OF THE CORNER AS SHOWN

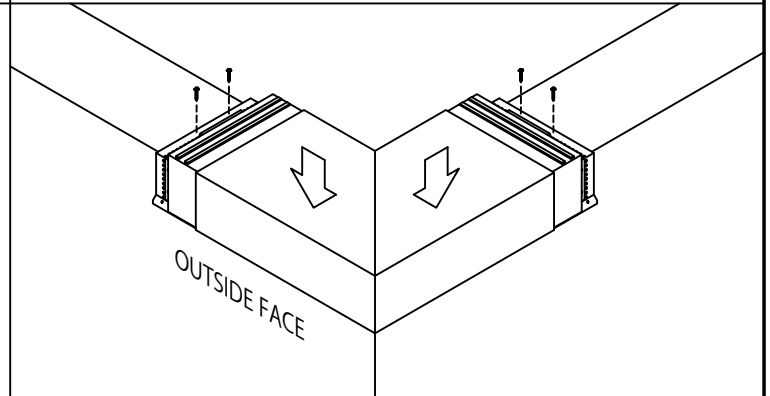

STEP 4 - MITER

PLACE THE CORNER ASSEMBLY INTO POSITION AND SECURE AT THE EXPOSED EDGE OF THE ANCHOR CLIPS AS PER DETAIL A.

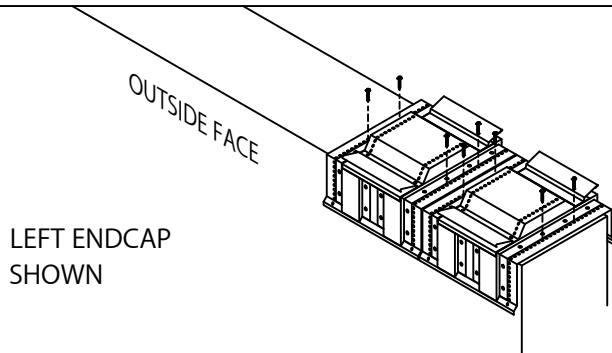

LEFT ENDCAP SHOWN

STEP 5 - ENDCAP ANCHOR CLIPS

LOCATE AND FASTEN GALVANIZED ANCHOR CLIPS TO WALL WITH PROVIDED FASTENERS FOR SUBSTRATE (SEE DETAIL A).

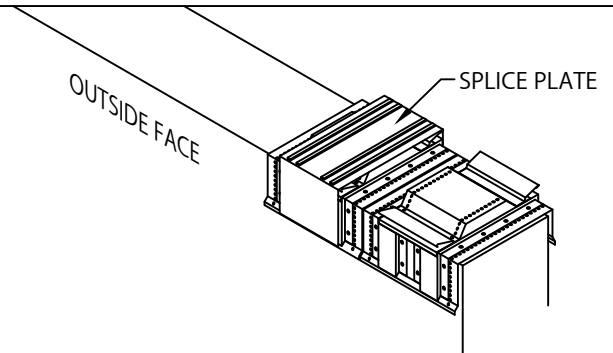

STEP 6 - ENDCAP SPLICE PLATES

REMOVE RELEASE PAPER FROM TOP OF FACTORY APPLIED SEALANT STRIPS. PLACE SPLICE PLATE ONTO SECOND ANCHOR CLIP AS SHOWN.

HICKMAN
an MTL company

Hickman Edge Systems
4 Commerce Way
Arden, NC 28704
Phone: 828-676-1700
www.hickmanedgesystems.com

DATE: 02/07/22
DRN BY: MLM
CKD BY: MM

SHT.# 1 OF 3
DWG# 64111-37818

A

PERMASNAP DUAL CANTILEVER COPING

3'-0" O.C.

INSTALLATION INSTRUCTIONS

OUTSIDE FACE

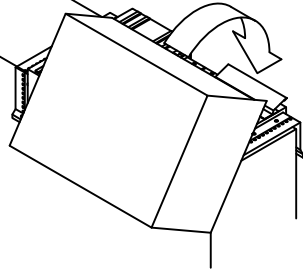

STEP 7 - ENDCAP

HOOK OUTSIDE FACE OF ENDCAP OVER THE ANCHOR CLIPS AND ROTATE INTO PLACE. ENGAGE REAR LEG ONTO ANCHOR CLIPS BY PRESSING DOWNWARD UNTIL SNAP LOCK OCCURS.

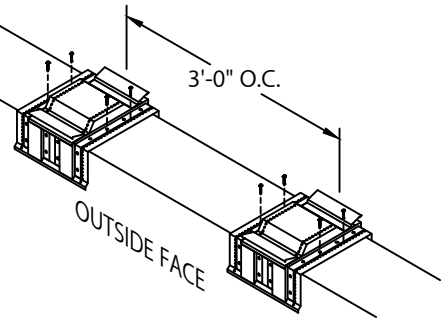

STEP 8 - ANCHOR CLIPS

LOCATE AND FASTEN GALVANIZED ANCHOR CLIPS TO WALL AT 3'-0" CENTERS WITH PROVIDED FASTENERS FOR SUBSTRATE (SEE DETAIL A).

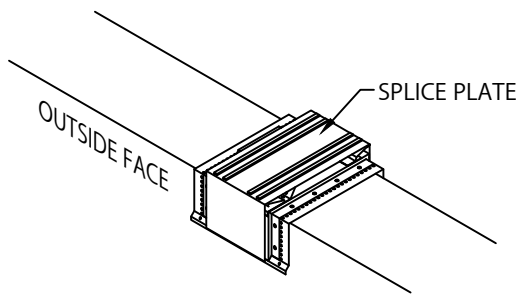

STEP 9 - SPLICE PLATES

PLACE SPLICE PLATE ONTO ANCHOR CLIPS AT SPLICE JOINTS, 12'-0" O.C.
NOTE: REMOVE RELEASE PAPER FROM SEALANT STRIPS.

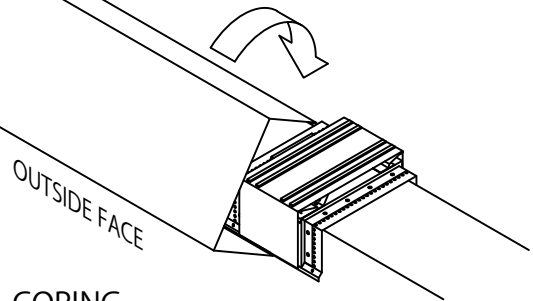

STEP 10 - COPING

HOOK OUTSIDE FACE OF COPING OVER THE ANCHOR CLIPS AND ROTATE INTO PLACE. ENGAGE REAR LEG ONTO ANCHOR CLIPS BY PRESSING DOWNWARD UNTIL SNAP LOCK OCCURS.

OUTSIDE FACE

3/8" SPACE

STEP 11 - COMPLETION

CONTINUE INSTALLING COPING WITH A 3/8" SPACE AT SPLICE JOINTS TO ALLOW FOR THERMAL EXPANSION. FIELD CUT WHERE NECESSARY USING FINE TOOTH HACKSAW OR SNIPS.
NOTE: REMOVE PROTECTIVE FILM IMMEDIATELY.

HICKMAN
an MTL company

Hickman Edge Systems
4 Commerce Way
Arden, NC 28704
Phone: 828-676-1700
www.hickmanedgesystems.com

DATE: 02/07/22

DRN BY: MLM

CKD BY: MM

SHT.# 2 OF 3

DWG# 64111-37818

A

PERMASNAP DUAL CANTILEVER COPING

3'-0" O.C.

INSTALLATION INSTRUCTIONS

TYPICAL COPING INSTALLATION DETAIL A

