

T-BAR FASCIA
TWO SLOT WITH FORMED BAR

NOTES

- Provided with Lap Notch
- For non-90 miters, see separate print approval
- Product should be installed per provided installation instructions

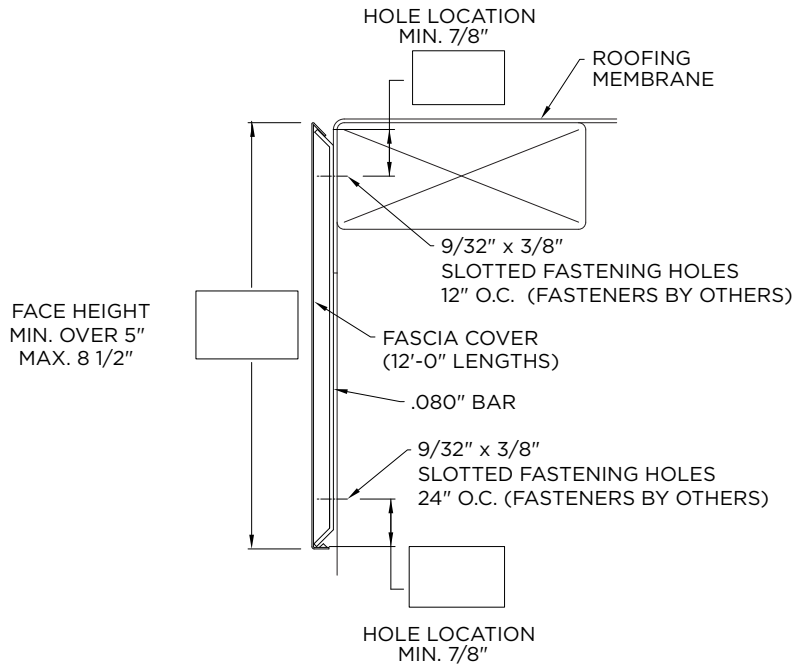

PROJECT INFO

Project Name: _____

Architect: _____

Roofing Contractor: _____

Project Type:

By selecting this box you have verified and confirmed that dimensions, sizes, and quantities are correct. All products will be installed in strict accordance with printed instructions.

Date: _____

Hickman Edge Systems
4 Commerce Way
Arden, NC 28704
Phone: 828-676-1700
www.hickmanedgesystems.com

SHT# 1 of 1

DATE: 03/21/22

DRN BY: JJC

CKD BY: MM

DWG #: 64010-37160

REV: A

DIMENSIONS

PLEASE FILL OUT DIMENSIONS ON DRAWING

MATERIAL

- 24 Ga. Galv. Steel
- 22 Ga. Galv. Steel
- .040" Aluminum

Color: _____
Finish: _____

OTHER: _____

QUANTITIES

_____ Lineal Feet (12'-0" Lengths)

_____ Outside Miters (90°)

_____ Inside Miters (90°)