



# PERMASNAP CONTINUOUS CLEAT COPING

TAPERED VERSION

## INSTALLATION INSTRUCTIONS

**IMPORTANT:** Prior to installation, read instructions carefully.

**NOTE:** Position roof membrane on top of the wall covering the treated wood nailer(s) or substrate completely. Allow 1/2" minimum excess membrane beyond nailer where applicable. NRCA requirement.

**CAUTION:** INSTALL MITERS FIRST!

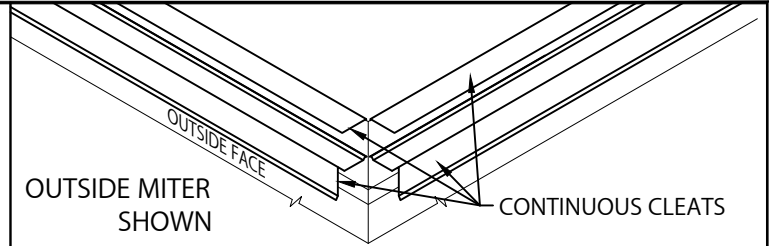

### STEP 1 - CONTINUOUS CLEATS AT CORNERS

PLACE OUTSIDE CONTINUOUS CLEATS ON BOTH SIDES OF CORNER AND TWO INSIDE CONTINUOUS CLEATS ON BOTH SIDES. DO NOT FASTEN CLEATS AT THIS TIME.

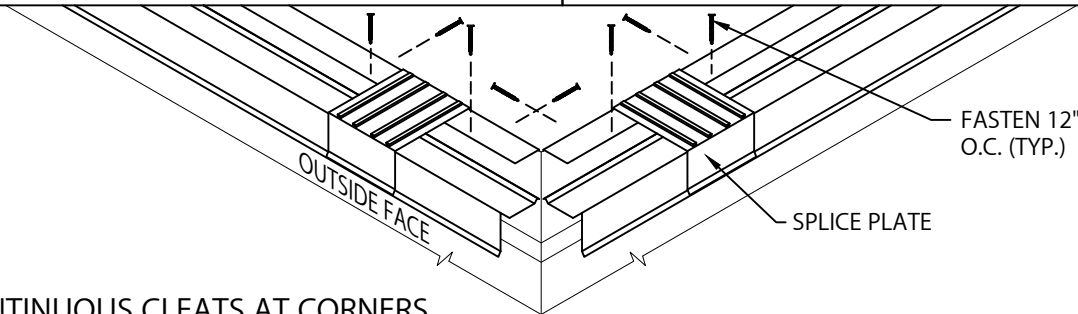

### STEP 2 - CONTINUOUS CLEATS AT CORNERS

USING A SPLICE PLATE AS A SPACER, FASTEN INSIDE CONTINUOUS CLEAT TO WALL AT 12" O.C. USING PROVIDED FASTENERS. FOR FASTENER LOCATION, SEE DETAIL A.

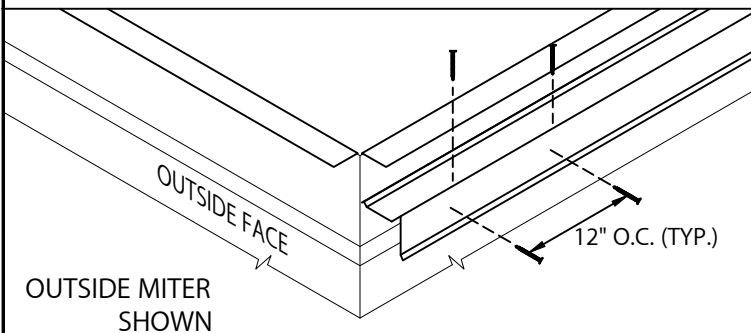

### STEP 3 - CONTINUOUS CLEATS AT CORNERS

FASTEN ONE OUTSIDE CONTINUOUS CLEAT 12" O.C. WITH PROVIDED FASTENERS (SEE DETAIL A).

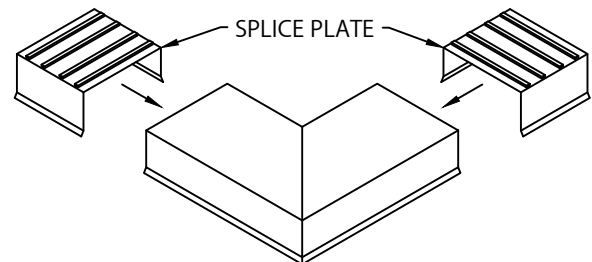

### STEP 4 - MITER SPLICE PLATES

REMOVE RELEASE PAPER FROM TOP OF FACTORY APPLIED SEALANT STRIPS. INSTALL THE SPLICE PLATES INTO EACH END OF THE MITER AS SHOWN

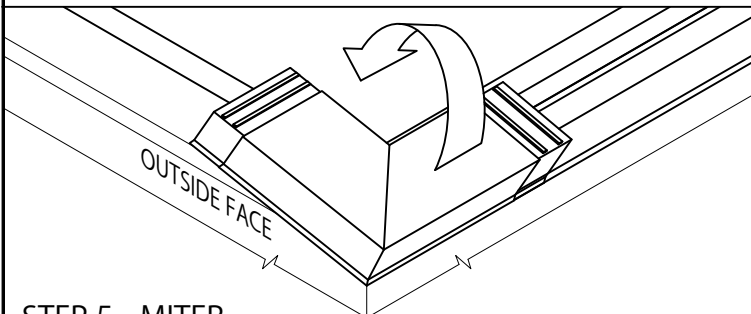

### STEP 5 - MITER

HOOK OUTSIDE FACE OF MITER ASSEMBLY ONTO CONTINUOUS CLEAT AND ROTATE INTO PLACE.

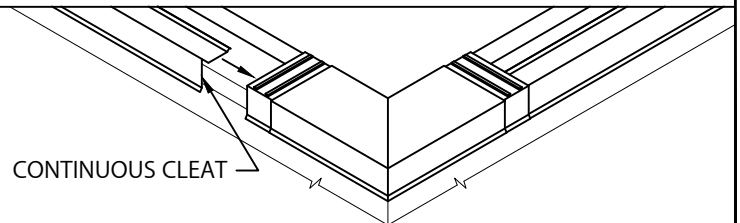

### STEP 6 - CONTINUOUS CLEAT

INSTALL FOURTH CONTINUOUS CLEAT BY SLIDING IT UNDER THE MITER, BEING SURE TO ENGAGE DRIPS. FASTEN TO THE WALL 12" O.C. WITH PROVIDED FASTENERS. FIELD CRIMP DRIP ON INSIDE FACE (SEE CRIMP DETAIL, STEP 9).



Hickman Edge Systems  
4 Commerce Way  
Arden, NC 28704  
Phone: 828-676-1700  
www.hickmanedgesystems.com

DATE: 02/04/22  
DRN BY: MLM  
CKD BY: MM

SHT.# 1 OF 3

DWG# 64111-37811

A



# PERMASNAP CONTINUOUS CLEAT COPING

TAPERED VERSION

## INSTALLATION INSTRUCTIONS

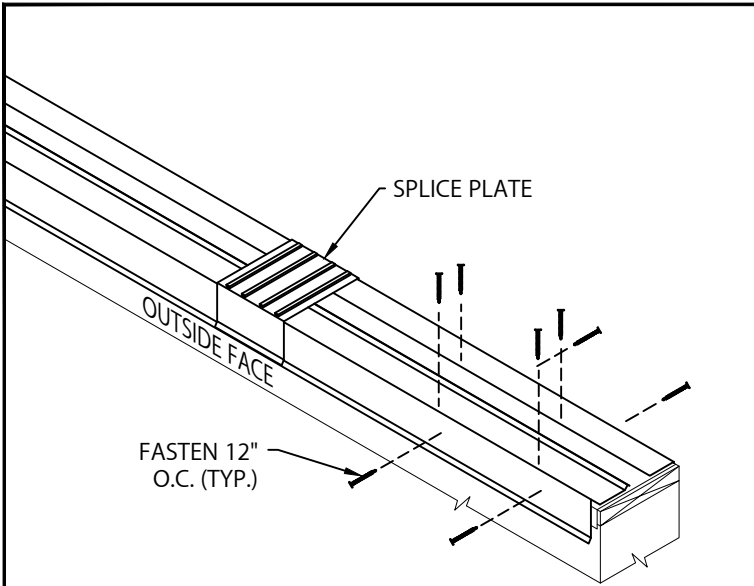

### STEP 7 - CONTINUOUS CLEATS

USING A SPLICE PLATE AS A SPACER AS SHOWN IN STEP 2, LOCATE CONTINUOUS CLEATS ALONG INSIDE AND OUTSIDE WALL AND FASTEN BOTH CLEATS 12" O.C. WITH PROVIDED FASTENERS.

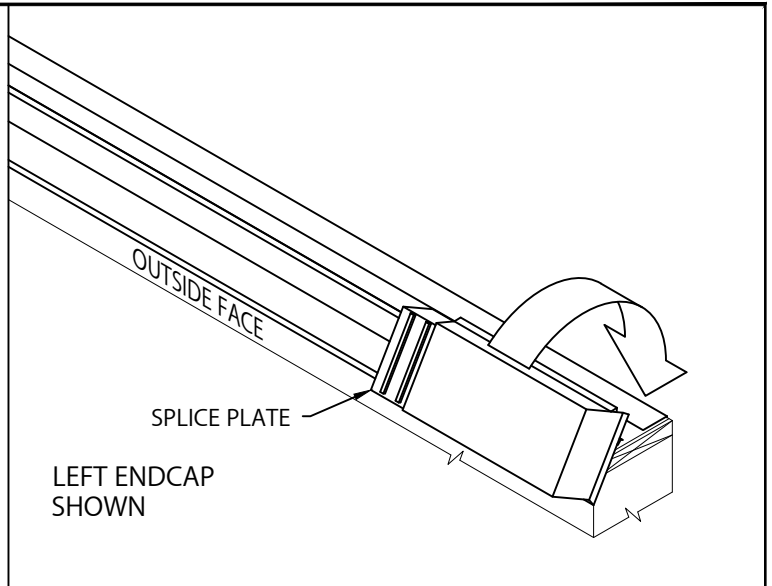

### STEP 8 - ENDCAPS

REMOVE RELEASE PAPER FROM SPLICE PLATE SEALANT STRIPS. PLACE SPLICE PLATE HALFWAY INTO ENDCAP. HOOK OUTSIDE FACE OF ENDCAP ONTO THE CONTINUOUS CLEAT AND ROTATE INTO PLACE. FIELD CRIMP DRIP ON INSIDE FACE (SEE CRIMP DETAIL, STEP 9).

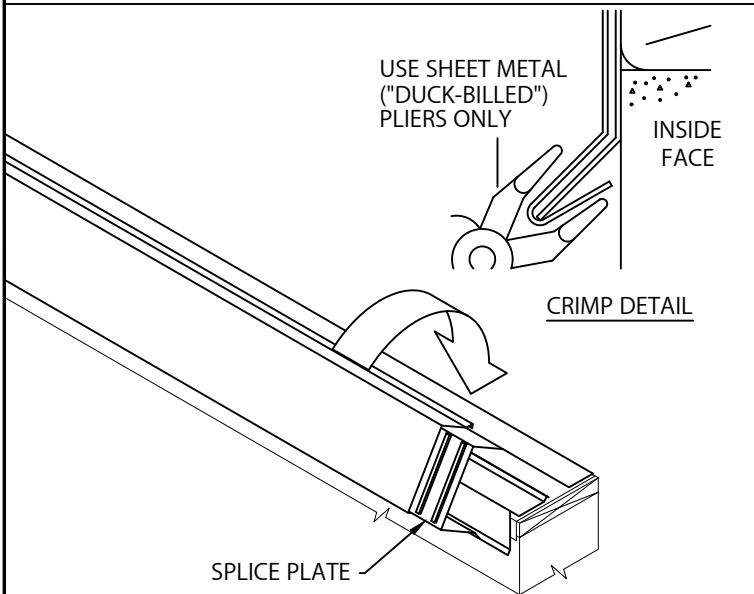

### STEP 9 - COPING SECTIONS

REMOVE SEALANT STRIPS FROM SPLICE PLATE AND PLACE INTO END OF 12'-0" COPING SECTION AS SHOWN. HOOK DRIP EDGE OF EACH COPING SECTION ONTO CONTINUOUS CLEAT, ROTATE INTO PLACE. FIELD CRIMP DRIP ON INSIDE FACE 18" O.C. (SEE CRIMP DETAIL). NOTE: REMOVE PROTECTIVE FILM IMMEDIATELY.

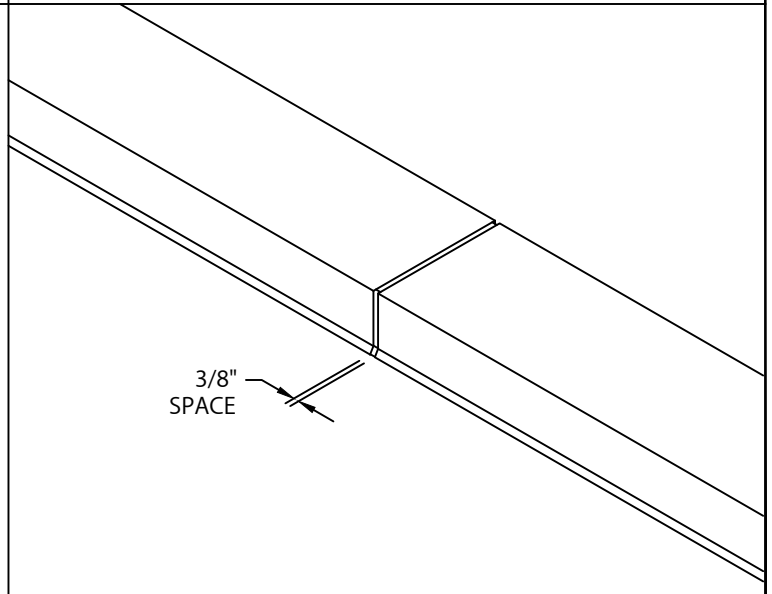

### STEP 10 - COPING SECTIONS

CONTINUE INSTALLING COPING WITH A 3/8" SPACE AT SPLICE JOINTS TO ALLOW FOR THERMAL EXPANSION. FIELD CUT WHERE NECESSARY USING A FINE TOOTH HACKSAW OR SNIPS. NOTE: REMOVE PROTECTIVE FILM IMMEDIATELY.



Hickman Edge Systems  
4 Commerce Way  
Arden, NC 28704  
Phone: 828-676-1700  
www.hickmanedgesystems.com

DATE: 02/04/22  
DRN BY: MLM  
CKD BY: MM

SHT.# 2 OF 3  
DWG# 64111-37811

A



# PERMASNAP CONTINUOUS CLEAT COPING

TAPERED VERSION

## INSTALLATION INSTRUCTIONS

### TYPICAL INSTALLATION

#### DETAIL A

