



TERMINEDGE ONE EXTENDED FASCIA

FULLY ADHERED OR MECHANICALLY ATTACHED SINGLE-PLY VERSION

SPLICE PLATE VERSION INSTALLATION INSTRUCTIONS

FOR RADIUS INSTALLATION INSTRUCTIONS SEE PAGE 7 & 8

TYPICAL INSTALLATION FOR 12'-0" STRAIGHT COVER

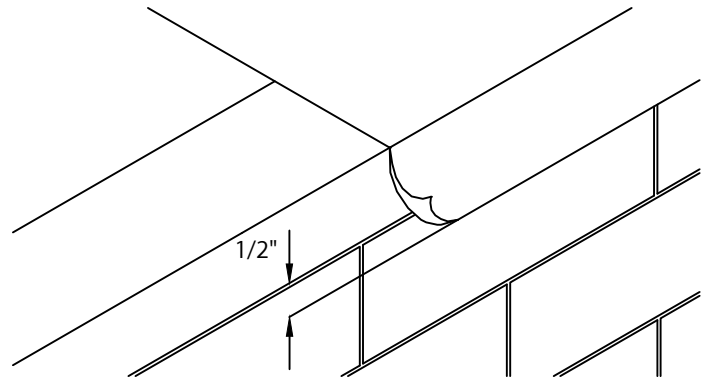
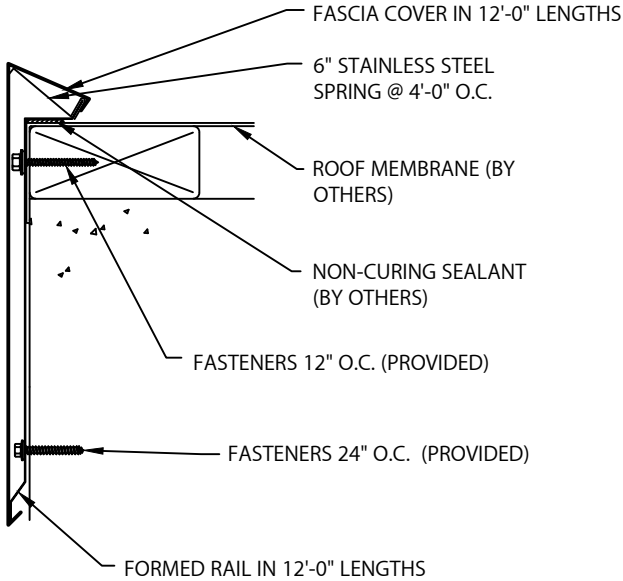

STEP 1 - MEMBRANE

POSITION MEMBRANE OVER THE ROOF EDGE AND DOWN THE OUTSIDE FACE OF THE WALL, OVERLAPPING THE NAILER(S) BY AT LEAST 1/2".

IMPORTANT! Outside edge of treated wood nailer(s) (minimum 2 x 4) shall be aligned flush with or extend slightly past outermost edge of wall. Fascia is for use as a perimeter securement on roof designs where the product is not installed in a waterline.

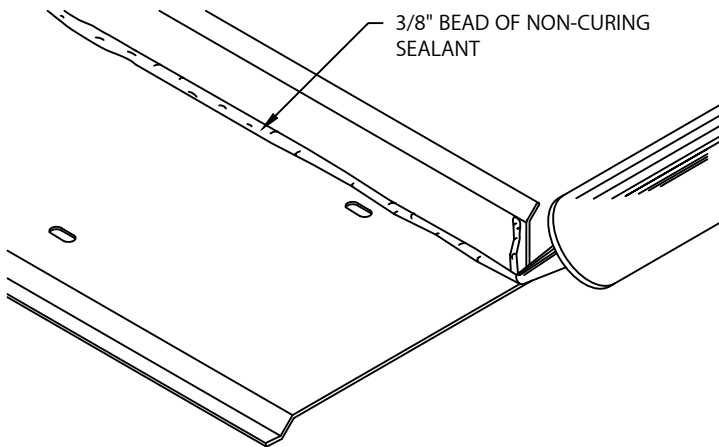

BASE RAIL SHOWN WITH INSIDE FACE UP.

STEP 2 - MITER & SCUPPER BASE RAIL (PREPARATION)

LAY THE BASE RAIL ON THE DECK WITH THE OUTSIDE FACE DOWN. IF NECESSARY, CLEAN THE BACK SIDE OF THE BASE RAIL OF DUST OR DIRT. APPLY A HEAVY 3/8" BEAD OF NON-CURING SEALANT TO THE RIGHT ANGLE INTERSECTION OF THE DECK FLANGE AND BASE RAIL THE ENTIRE LENGTH OF BASE RAIL AS SHOWN. APPLY A SIMILAR 3/8" BEAD OF SEALANT TO THE BOTTOM OF THE FLANGE'S LEFT END, AS YOU LOOK AT THE OUTSIDE FACE OF THE BASE RAIL SECTION.

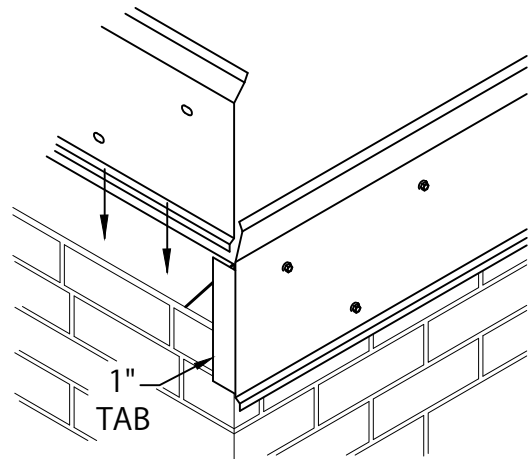

STEP 3 - RAIL MITER PREPARATION

SEE PAGE 5 FOR MITER PREPARATION. FASTEN MITER BASE RAIL TO NAILER(S) THROUGH BASE RAIL SLOTS WITH PROVIDED FASTENERS.



TERMINEDGE ONE EXTENDED FASCIA

FULLY ADHERED OR MECHANICALLY ATTACHED SINGLE-PLY VERSION

SPLICE PLATE VERSION INSTALLATION INSTRUCTIONS

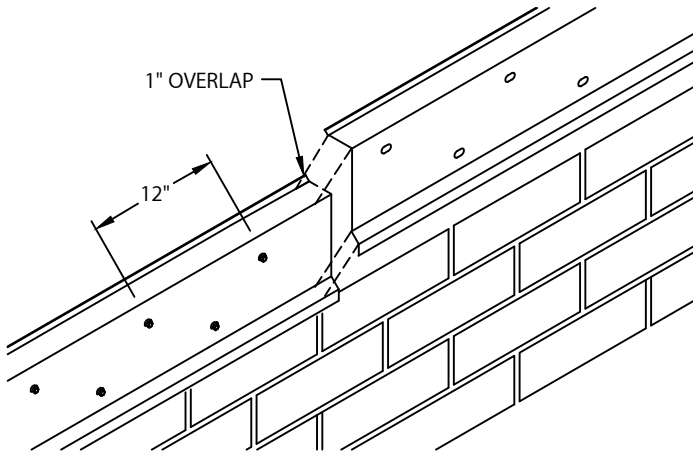

STEP 4 - BASE RAIL INSTALLATION

INSTALL 12'-0" SECTION OF BASE RAIL FROM RIGHT TO LEFT AS SEEN FROM ROOF TOP, LAPPING THE PREVIOUS SECTION 1". FASTEN BASE RAIL TO NAILER(S) THROUGH BASE RAIL SLOTS 12" O.C. AND 24" O.C. WITH PROVIDED FASTENERS. FIELD CUT THE BASE RAIL SECTIONS AS NEEDED.

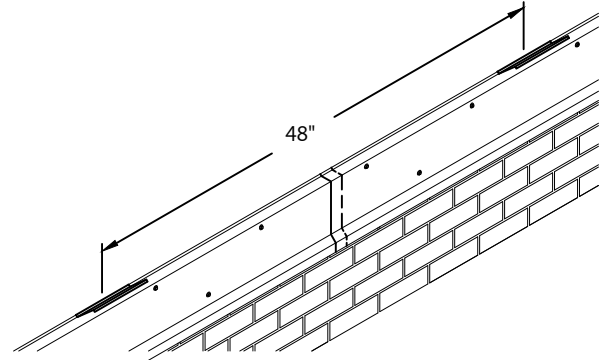

STEP 5 - SPRING CLIPS

PLACE 6" SPRINGS 4'-0" O.C., MAKING SURE THERE WILL BE A SPRING CLIP UNDER EACH FASCIA COVER END.

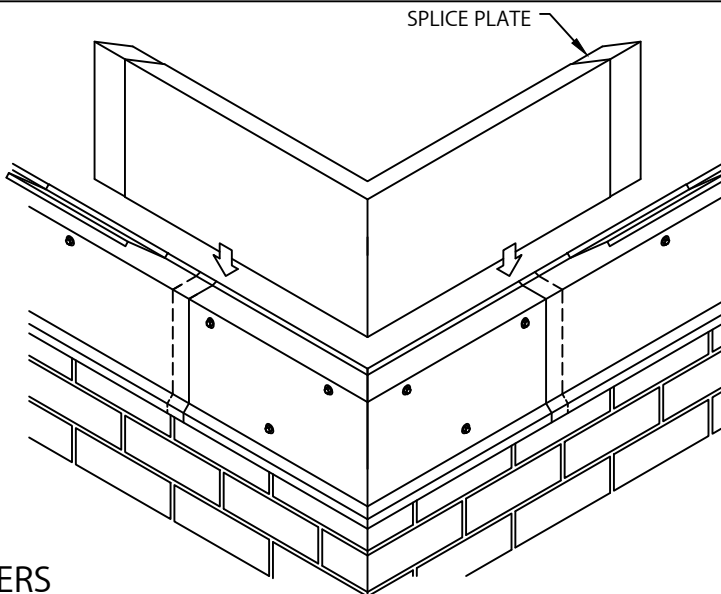

STEP 6 - MITERS

PLACE SPLICE PLATE INTO EACH END OF MITER COVER. SIMPLY POSITION THE COVER ABOVE THE RAIL AND WITH PALM OF HAND APPLY SLIGHT PRESSURE DOWNWARD UNTIL ENGAGED TO THE BOTTOM OF BASE RAIL. IF MITERS ARE NOT SUPPLIED, SEE PAGE 6 FOR FABRICATION INSTRUCTIONS.



TERMINEDGE ONE EXTENDED FASCIA

FULLY ADHERED OR MECHANICALLY ATTACHED SINGLE-PLY VERSION

SPLICE PLATE VERSION INSTALLATION INSTRUCTIONS

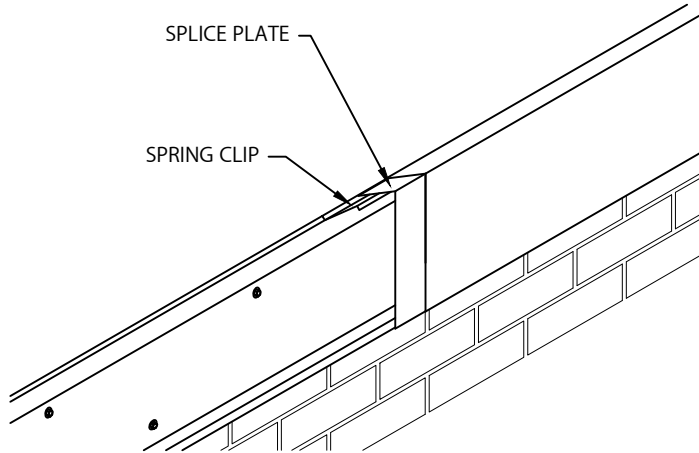

STEP 7 - SPLICE PLATES

REMOVE THE PROTECTIVE FILM FROM FASCIA COVERS.
FASCIA COVERS SHALL BE INSTALLED FROM LEFT TO RIGHT AS SEEN FROM ROOFTOP. PLACE SPLICE PLATE IN RIGHT END OF COVER. SNAP RIGHT COVER ONTO BASE RAIL BY APPLYING DOWNWARD PRESSURE WITH PALM OF HAND UNTIL THE FASCIA COVER IS FULLY ENGAGED ALONG ENTIRE LENGTH. FIELD CUT COVERS AS REQUIRED WITH FINE TOOTH HACKSAW.

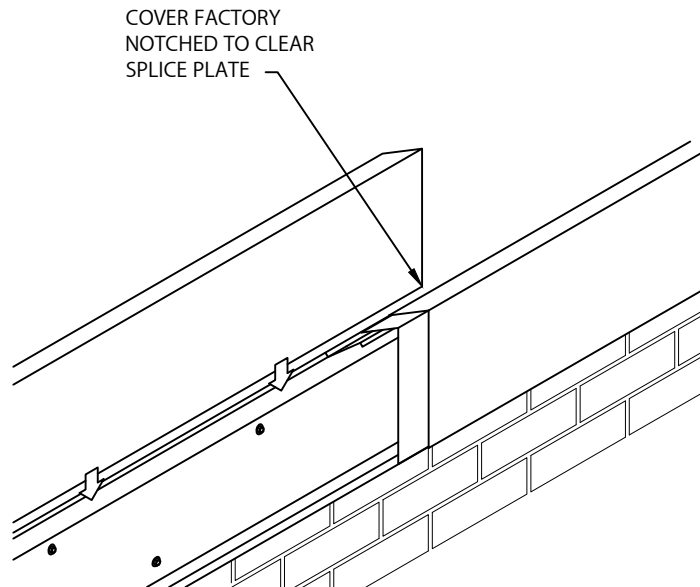

STEP 8 - FASCIA COVERS

POSITION PRE-NOTCHED COVER AND SNAP ONTO BASE RAIL BY PRESSING DOWN WITH THE PALM OF YOUR HAND UNTIL THE COVER IS FULLY ENGAGED ALONG THE ENTIRE LENGTH. ALLOW A 3/8" GAP BETWEEN COVER SECTIONS. FIELD CUT WHERE NECESSARY USING A FINE TOOTH HACKSAW.



TERMINEDGE ONE EXTENDED FASCIA

FULLY ADHERED OR MECHANICALLY ATTACHED SINGLE-PLY VERSION

SPLICE PLATE VERSION INSTALLATION INSTRUCTIONS

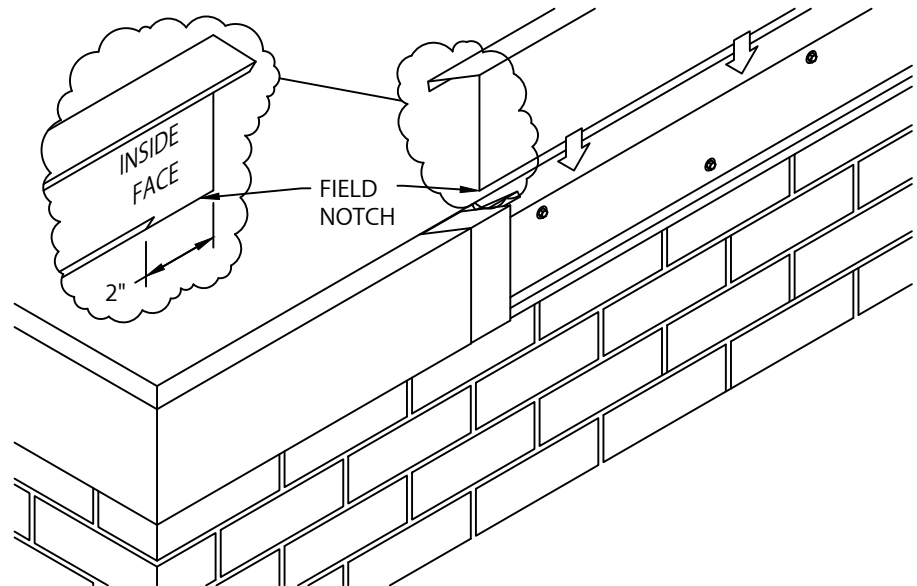

STEP 9 - FASCIA COVERS

AT MITER, FIELD NOTCH RIGHT SIDE OF COVER AS SHOWN. SNAP ONTO BASE RAIL BY PRESSING DOWN WITH THE PALM OF YOUR HAND UNTIL THE COVER IS FULLY ENGAGED ALONG THE ENTIRE LENGTH. ALLOW 3/8" BETWEEN COVER SECTIONS. FIELD CUT WHERE NECESSARY USING THE FINE TOOTH HACKSAW.



TERMINEDGE ONE EXTENDED FASCIA

FULLY ADHERED OR MECHANICALLY ATTACHED SINGLE-PLY VERSION

SPLICE PLATE VERSION INSTALLATION INSTRUCTIONS

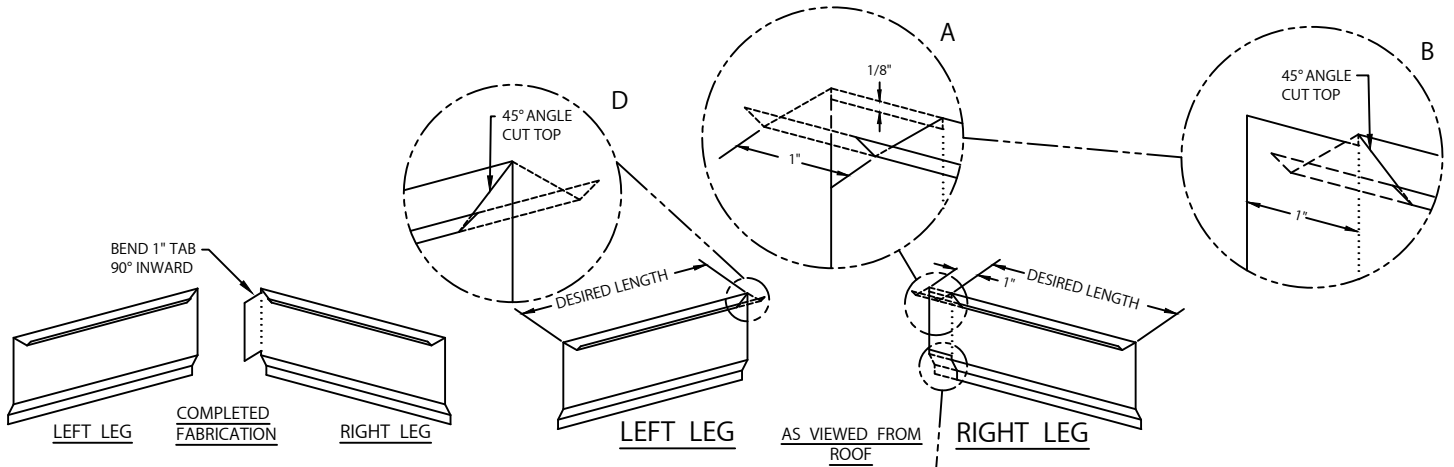

STEP 10 - OUTSIDE MITER RAIL FABRICATION (CUT RAIL TO DESIRED LENGTH)

RIGHT LEG - DETAIL A: FIRST REMOVE A 1" SECTION FROM TOP FLANGE, 1/8" DOWN FACE AND 1" HORIZONTALLY AS SHOWN TO CREATE TAB.

DETAIL B: CUT TOP FLANGE AT A 45° ANGLE. **DETAIL C:** CUT OFF BOTTOM FACE 1/8" x 1" AS SHOWN AND CONTINUE THROUGH AREA SHOWN ON BOTTOM FLANGE. BEND TAB INWARDS 90°.

LEFT LEG - DETAIL D: TRIM TOP FLANGE AT A 45° ANGLE.

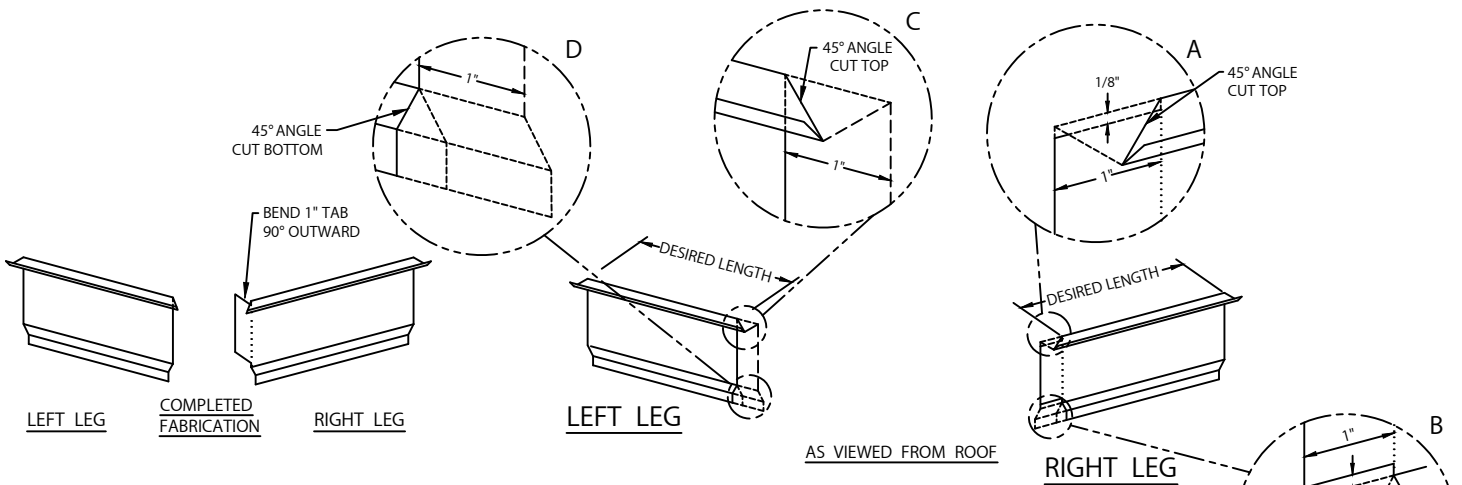

STEP 11 - INSIDE MITER RAIL FABRICATION (CUT RAIL TO DESIRED LENGTH)

RIGHT LEG - DETAIL A: FIRST REMOVE SECTION 1/8" DOWN AND 1" HORIZONTALLY AS SHOWN TO CREATE TAB. TRIM TOP FLANGE BACK AT A 45° ANGLE. **DETAIL B:** CUT OFF BOTTOM FACE 1/8" AS SHOWN AND CONTINUE CUT AT A 45° ANGLE THROUGH AREA SHOWN ON BOTTOM FLANGE.

LEFT LEG - DETAIL C: CUT TOP FLANGE AT A 45° ANGLE. CONTINUE DOWN FACE. **DETAIL D:** CUT BOTTOM FLANGE AT A 45° ANGLE AS SHOWN.



TERMINEDGE ONE EXTENDED FASCIA

FULLY ADHERED OR MECHANICALLY ATTACHED SINGLE-PLY VERSION

SPLICE PLATE VERSION INSTALLATION INSTRUCTIONS

STEP 12 - OUTSIDE MITER COVER FABRICATION (CUT COVER TO DESIRED LENGTH)

RIGHT LEG - DETAIL A: CREATE TAB BY REMOVING 1" PORTION OF TOP FLANGE AND EXTEND REMOVAL 1/8" DOWN FACE.

DETAIL B: CUT TOP FLANGE AT ANGLE 2" AS SHOWN. DETAIL C: CUT LOWER FLANGE AT AN ANGLE 3/4" AS SHOWN.

BEND 1" TAB 90° INWARD AS SHOWN.

LEFT LEG - DETAIL D: CUT TOP FLANGE AT ANGLE 2" AS SHOWN. DETAIL E: CUT LOWER FLANGE AT AN ANGLE 3/4" AS SHOWN.

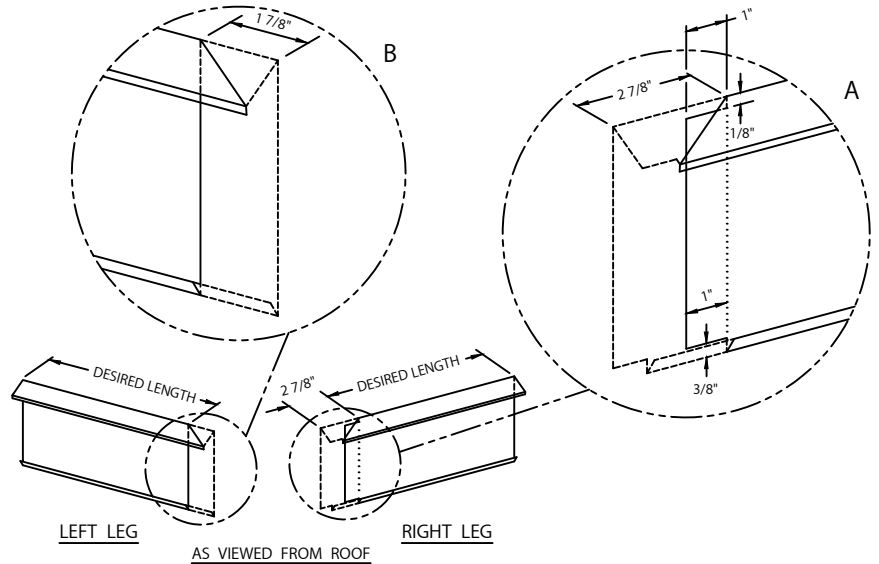
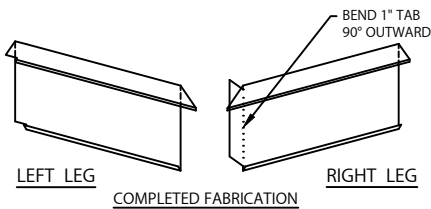
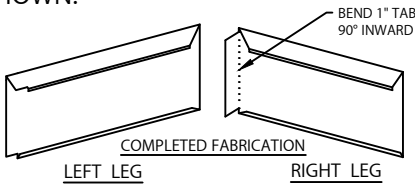
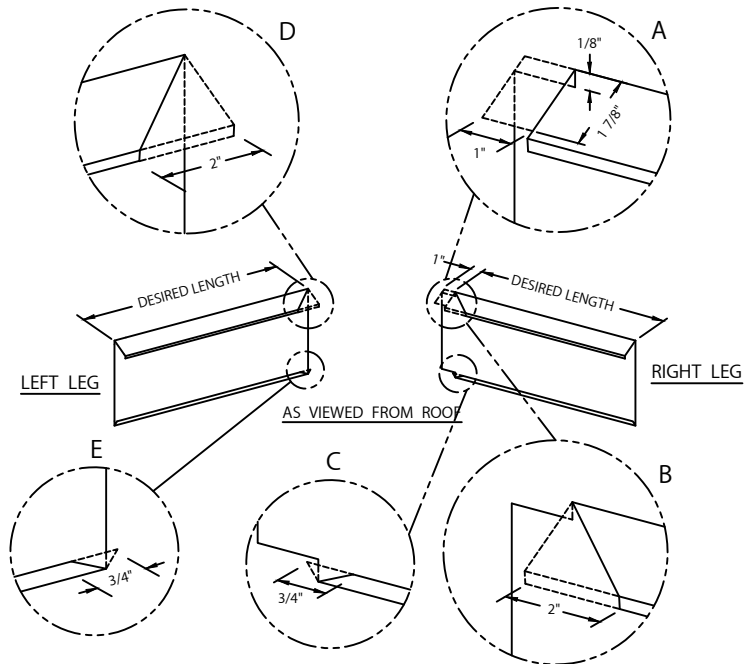

STEP 13 - INSIDE MITER COVER FABRICATION (CUT COVER TO DESIRED LENGTH)

RIGHT LEG - DETAIL A: CREATE TAB BY CUTTING TOP FLANGE AT ANGLE 2 7/8" AS SHOWN. CUT 1/8" DOWN FACE AND 1" HORIZONTALLY. CUT DOWNWARD THROUGH FACE AND CONTINUE CUTTING TO WITHIN 3/8" FROM BOTTOM FLANGE.

CUT 1" HORIZONTALLY AS SHOWN, THEN CUT THROUGH BOTTOM FLANGE. BEND 1" TAB 90° OUTWARD AS SHOWN.

LEFT LEG : DETAIL B: TRIM BACK THE TOP FLANGE ON ANGLE 1 7/8". PROCEED CUTTING THROUGH FRONT FACE AS SHOWN.



TERMINEDGE ONE EXTENDED FASCIA

FULLY ADHERED OR MECHANICALLY ATTACHED SINGLE-PLY VERSION

RADIUS INSTALLATION INSTRUCTIONS: SPLICE PLATE VERSION

RADIUS INSTALLATION INSTRUCTIONS

TYPICAL INSTALLATION

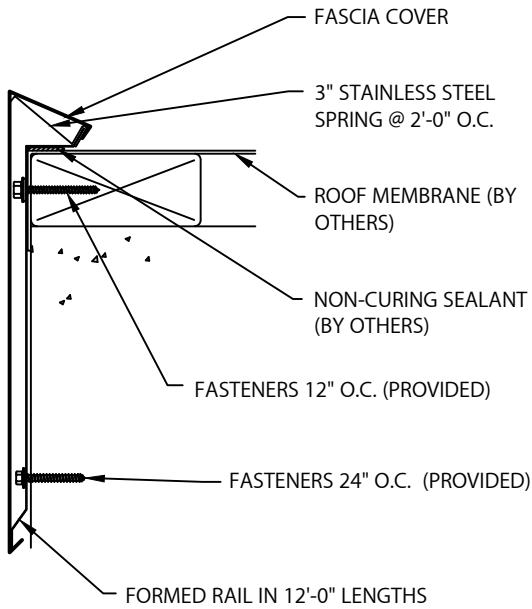

STEP 1

FOLLOW DIRECTIONS ON PAGE 1 FOR INSTALLING ROOF MEMBRANE & RAIL.

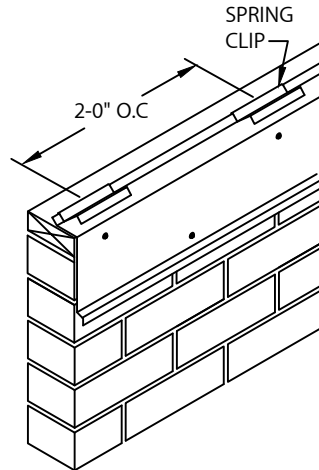

STEP 2 - SPRING CLIPS

LOCATE 3" WIDE SPRING CLIPS, STARTING WITH ONE AT THE END OF RAIL, THEN AT EVERY 2'-0" O.C., MAKING SURE THERE WILL BE A SPRING CLIP UNDER EACH FASCIA COVER END.

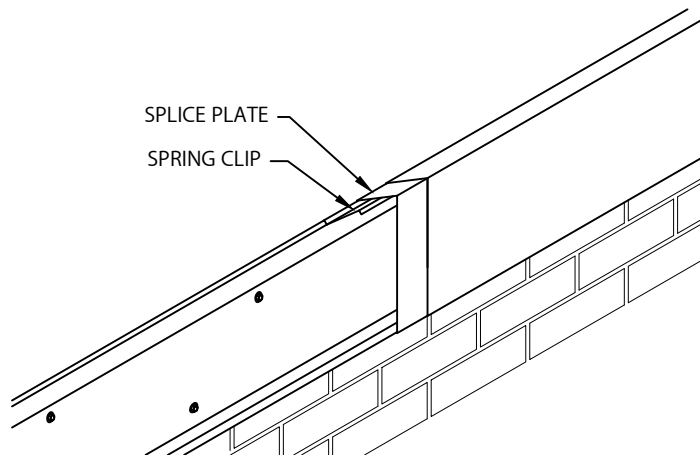

STEP 3 - SPLICE PLATES

REMOVE THE PROTECTIVE FILM FROM FASCIA COVERS. FASCIA COVERS SHALL BE INSTALLED FROM LEFT TO RIGHT (AS IN STEP 7 ON PAGE 3). PLACE SPLICE PLATE IN RIGHT END OF THE COVER. SNAP RIGHT COVER ONTO BASE RAIL BY APPLYING DOWNWARD PRESSURE WITH PALM OF HAND UNTIL THE FASCIA COVER IS FULLY ENGAGED ALONG ENTIRE LENGTH. FIELD CUT COVERS AS REQUIRED WITH FINE TOOTH HACKSAW.



TERMINEDGE ONE EXTENDED FASCIA

FULLY ADHERED OR MECHANICALLY ATTACHED SINGLE-PLY VERSION

RADIUS INSTALLATION INSTRUCTIONS: SPLICE PLATE VERSION

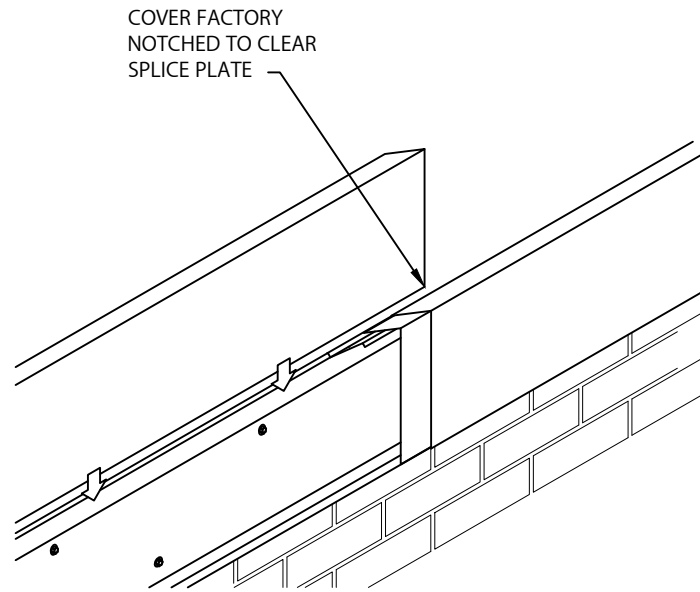

STEP 4 - FASCIA COVERS

POSITION PRE-NOTCHED COVER AND SNAP ONTO BASE RAIL BY PRESSING DOWN WITH THE PALM OF YOUR HAND UNTIL THE COVER IS FULLY ENGAGED ALONG THE ENTIRE LENGTH. ALLOW A 3/8" GAP BETWEEN COVER SECTIONS. FIELD CUT WHERE NECESSARY USING A FINE TOOTH HACKSAW.