

CORRUGATED DOWNSPOUT

4" X 5"

NOTES

- Downspout should be 9/16" smaller than the bottom of the gutter
- Outlet should be 1/8" smaller than the size of the downspout
- Product should be installed per provided installation instructions

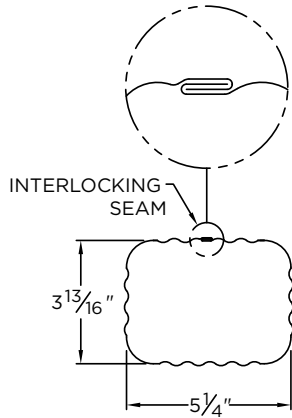

DOWNSPOUT SECTION
10'-0" LENGTHS

2 1/4" WIDE DOWNSPOUT STRAPS
(2 PER 10'-0" LENGTH)

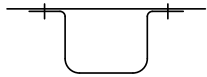

STYLE "A" ELBOW

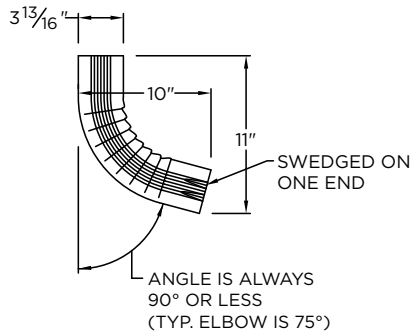

STYLE "B" ELBOW
RIGHT

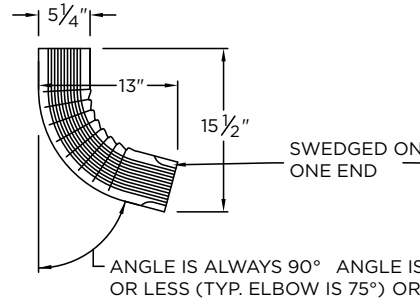

STYLE "B" ELBOW
LEFT

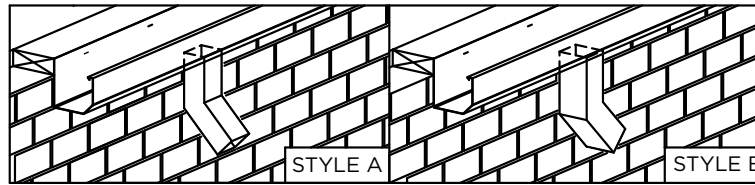
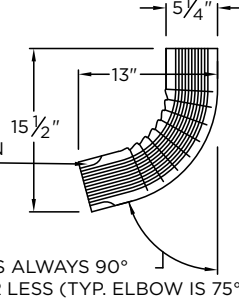

DOWNSPOUT MATERIAL

- 24 Ga. Galv. Steel Color: _____
- 22 Ga. Galv. Steel Finish: _____
- .032" Aluminum
- .040" Aluminum
- OTHER: _____

ELBOW MATERIAL

- 24 Ga. Galv. Steel
- .032 Aluminum
- OTHER: _____
- Color: _____
- Finish: _____

QUANTITIES

- _____ Lineal Feet (10'-0" Lengths)
- _____ Outlets
- _____ Standard A Elbows (_____°)
- _____ Standard B Elbows-Right (_____°)
- _____ Standard B Elbows-Left (_____°)

PROJECT INFO

Project Name: _____

Architect: _____

Roofing Contractor: _____

Project Type: _____

By selecting this box you have verified and confirmed that dimensions, sizes, and quantities are correct. All products will be installed in strict accordance with printed instructions.

Date: _____

Hickman Edge Systems

4 Commerce Way
Arden, NC 28704
Phone: 828-676-1700
www.hickmanedgesystems.com

SHT# 1 of 1

DATE: 10/26/21

DRN BY: JJC

CKD BY: MM

DWG #: 64013-36794

REV: A