



# ELEVATE QUICKLOCK RADIUS COPING

EXISTING SLOPE VERSION

**IMPORTANT!!!** MUST INDICATE PROPER RADIUS CONDITION BY CIRCLING APPROPRIATE OUTSIDE FACE

PROVIDING A RADIUS  
THE RADIUS MAY BE PROVIDED  
IN ONE OF TWO METHODS:

1.) THE ACTUAL KNOWN RADIUS IS

\_\_\_\_\_ ' FEET \_\_\_\_\_ " INCHES

MINIMUM  
OF 3'-0"

OR

2.) FIELD CONDITION MEASUREMENTS

NOTE: REFER TO ATTACHED WORKSHEET  
FOR FURTHER INFORMATION

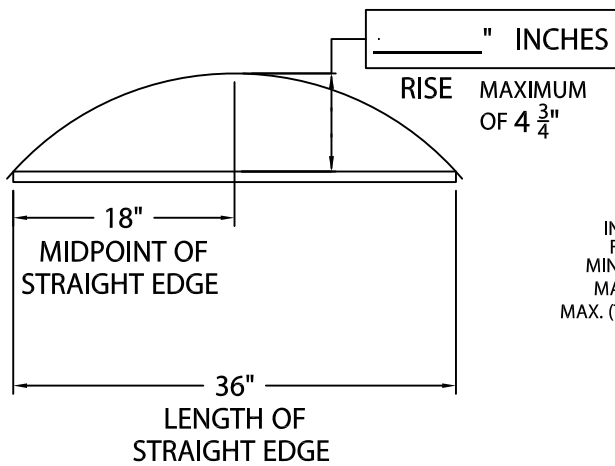

NOTE: CHECK MEASUREMENTS ALONG ENTIRE RADIUS.

DETAIL A

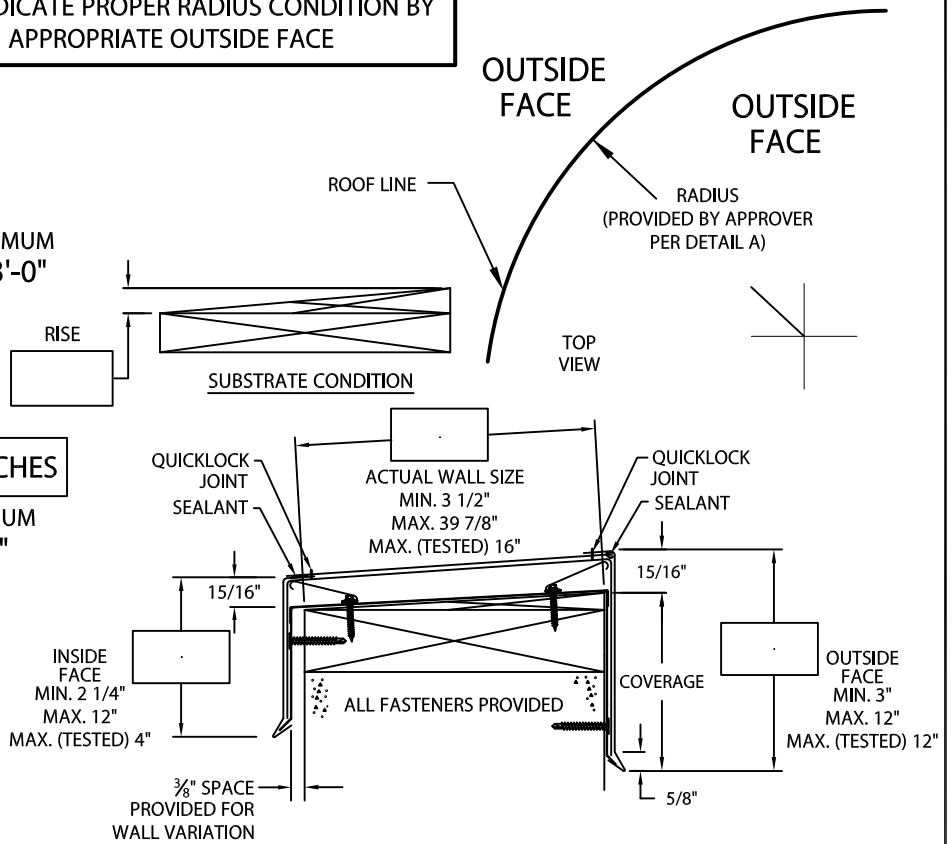

PLEASE SPECIFY SUBSTRATE:  
(IF SUBSTRATE INFORMATION  
IS NOT GIVEN, WOOD SUBSTRATE  
FASTENERS WILL BE PROVIDED)

WOOD

MASONRY

METAL

**NOTES:** -- CONCEALED SPLICE PLATES ARE PROVIDED WITH FACTORY APPLIED DUAL NON-CURING SEALANT STRIPS.

-- FABRICATION OF RADIUS IS FURNISHED UTILIZING A NON-PENETRATING QUICKLOCK JOINT, THEN FACTORY SEALED WATERTIGHT.

### MATERIAL:

\_\_\_ 24 GA. STEEL                      \_\_\_ .050" ALUMINUM

\_\_\_ .040" ALUMINUM                \_\_\_ .063" ALUMINUM

\_\_\_ OTHER \_\_\_\_\_

COLOR: \_\_\_\_\_

FINISH: \_\_\_\_\_

### QUANTITIES:

\_\_\_\_\_ LINEAL FEET 4'-0" LENGTHS

Fabrication will proceed only after receipt of signed print approval.

## Print Approval:

Architect and/or contractor shall verify all dimensions, sizes and quantities. All products to be installed in strict accordance with Elevate's printed instructions.

Approved by: \_\_\_\_\_

Date: \_\_\_\_\_

PROJECT:

ARCHITECT:

ROOFING CONTRACTOR:

REPRESENTATIVE/DISTRIBUTOR:



ELEVATE  
26 CENTURY BLVD.  
SUITE 205  
NASHVILLE, TN 37214  
CONTACT YOUR LOCAL ELEVATE REPRESENTATIVE

DATE: 03/16/23

DRN BY: MLM

CKD BY: MM

SHT.# \_\_\_\_\_ OF \_\_\_\_\_

DWG# 13011-40459

**A**