

HALF ROUND GUTTER

VERTICAL FASCIA, FIELD NOTCH LAP JOINT VERSION

INSTALLATION INSTRUCTIONS

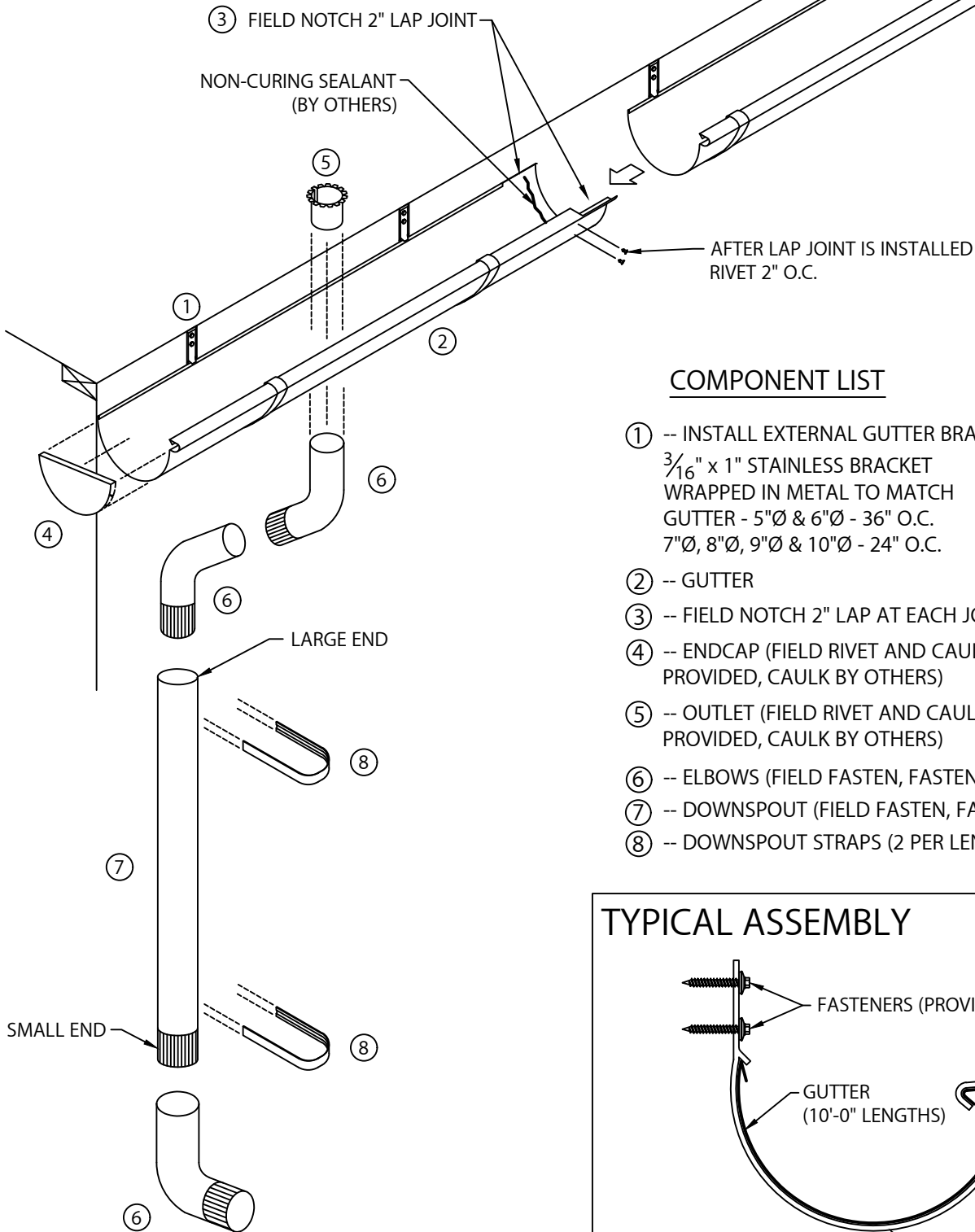

COMPONENT LIST

- ① -- INSTALL EXTERNAL GUTTER BRACKETS FIRST
 $\frac{3}{16}$ " x 1" STAINLESS BRACKET
 WRAPPED IN METAL TO MATCH
 GUTTER - 5"Ø & 6"Ø - 36" O.C.
 7"Ø, 8"Ø, 9"Ø & 10"Ø - 24" O.C.
- ② -- GUTTER
- ③ -- FIELD NOTCH 2" LAP AT EACH JOINT
- ④ -- ENDCAP (FIELD RIVET AND CAULK, RIVETS
 PROVIDED, CAULK BY OTHERS)
- ⑤ -- OUTLET (FIELD RIVET AND CAULK, RIVETS
 PROVIDED, CAULK BY OTHERS)
- ⑥ -- ELBOWS (FIELD FASTEN, FASTENERS BY OTHERS)
- ⑦ -- DOWNSPOUT (FIELD FASTEN, FASTENERS BY OTHERS)
- ⑧ -- DOWNSPOUT STRAPS (2 PER LENGTH)

TYPICAL ASSEMBLY

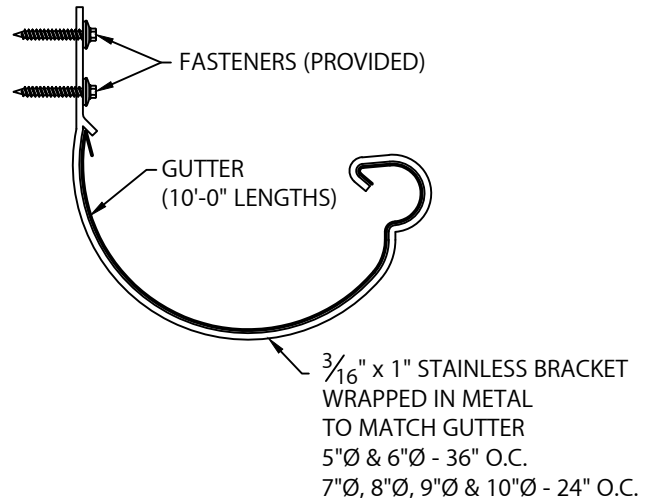

HALF ROUND GUTTER

VERTICAL FASCIA, FIELD NOTCH LAP JOINT VERSION

INSTALLATION INSTRUCTIONS

INSTALLING GUTTER INTO EXTERNAL GUTTER BRACKET

