

PLEASE READ

TECH BULLETIN: “PINKING” OF TPO PRODUCTS

You may notice a pink, red or orangish coloration called "pinking" on the surface of TPO products and samples. Please note that this is a **temporary** coloration. The “pinking” **will** go away within 24 hours of being installed once it is exposed to UV light. It’s important that the product is **installed** and **exposed completely** for the UV light to reach the full product.

Many TPO products contain a stabilization/weathering package which includes very powerful antioxidants that help protect the finished product from degradation due to heat induced thermal oxidation and sunlight induced photo-oxidation. Certain antioxidants in some weathering packages are particularly effective, but they are susceptible to pinking under the right environmental conditions, usually during storage. Pinking or "gas fading" is a surface reaction of these antioxidants with air pollutants, mostly nitrous oxides and sulfur oxides, produced in combustion processes. Pinking occurs over time on unweathered TPO surfaces that are exposed to polluted air, particularly in the absence of light.

As mentioned this is a temporary condition. The pinking will disappear upon exposure to sunlight and weathering in general once the product is completely installed. The products are not stained or permanently discolored in any way.



DRIP EDGE FASCIA

TPO OR PVC VERSION WITH CONTINUOUS CLEAT

NOTE: INSTALL MITERS FIRST

INSTALLATION INSTRUCTIONS

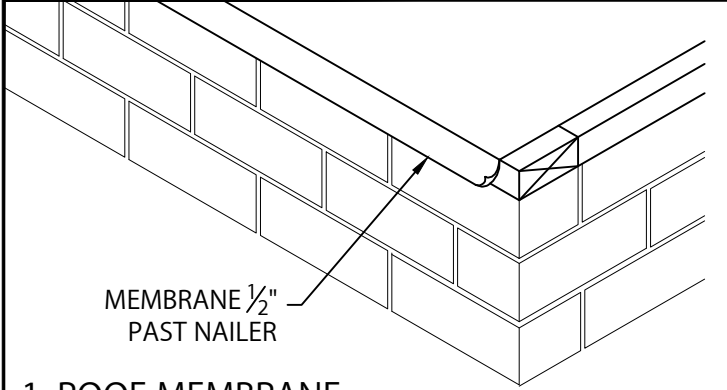

1. ROOF MEMBRANE

POSITION MEMBRANE OVER THE ROOF EDGE AND DOWN OUTSIDE FACE OF WALL, COVERING WOOD NAILER(S) COMPLETELY. ALLOW $\frac{1}{2}$ " EXCESS MEMBRANE.

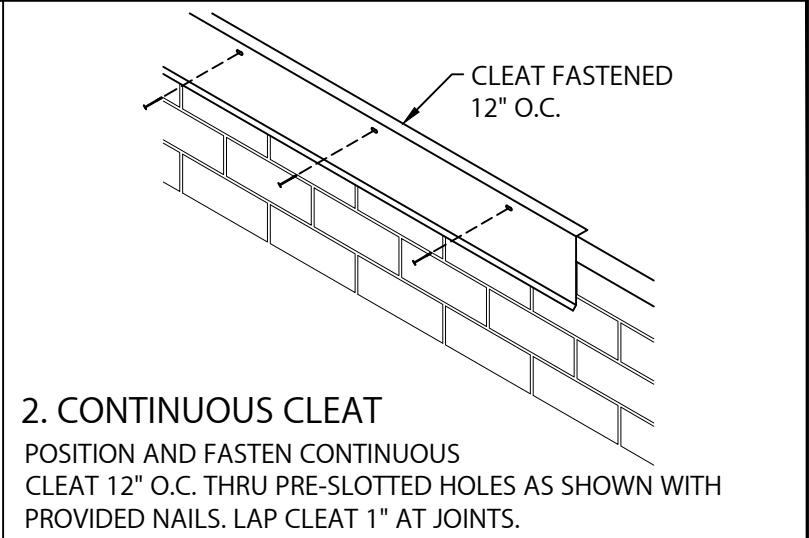

2. CONTINUOUS CLEAT

POSITION AND FASTEN CONTINUOUS CLEAT 12" O.C. THRU PRE-SLOTTED HOLES AS SHOWN WITH PROVIDED NAILS. LAP CLEAT 1" AT JOINTS.

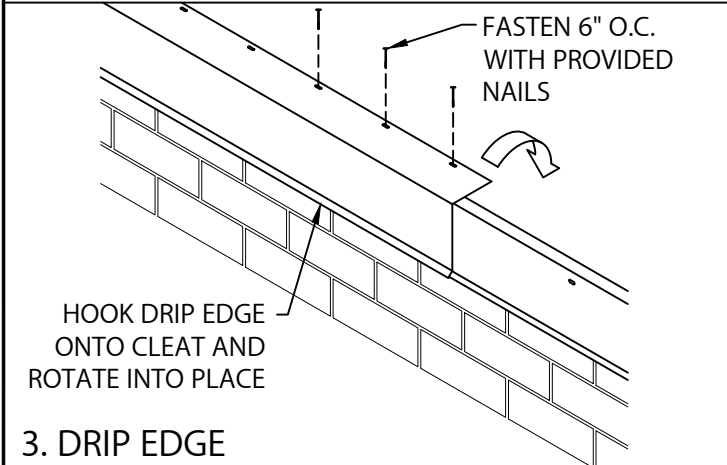

3. DRIP EDGE

HOOK DRIP EDGE OF EACH DRIP EDGE SECTION ONTO CONTINUOUS CLEAT, ROTATE INTO PLACE. FASTEN THRU PRE-SLOTTED HOLES 6" WITH PROVIDED NAILS.

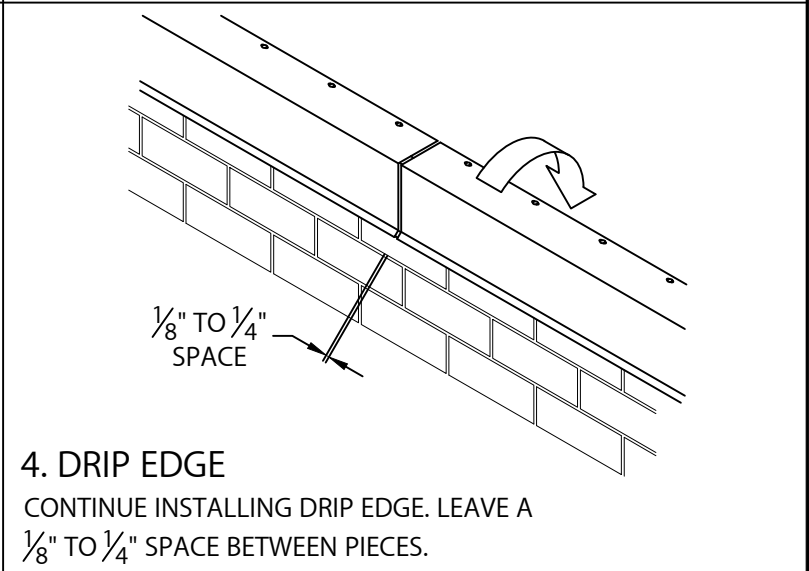

4. DRIP EDGE

CONTINUE INSTALLING DRIP EDGE. LEAVE A $\frac{1}{8}$ " TO $\frac{1}{4}$ " SPACE BETWEEN PIECES.

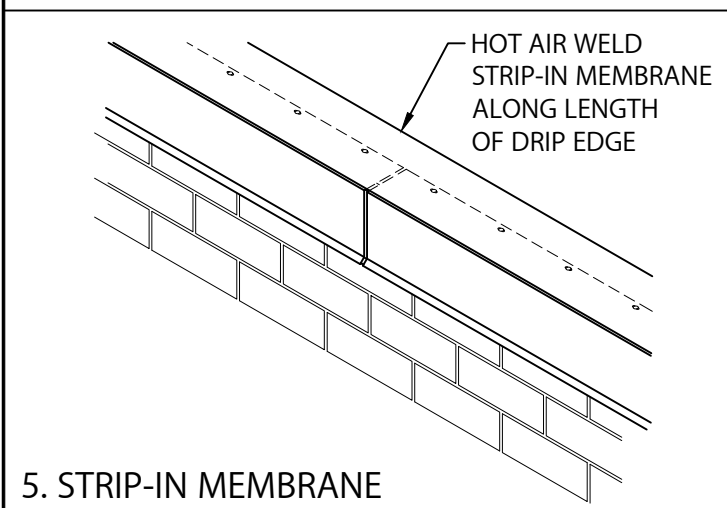

5. STRIP-IN MEMBRANE

HOT AIR WELD STRIP-IN MEMBRANE ALONG ENTIRE LENGTH OF DRIP EDGE PER MANUFACTURERS INSTRUCTIONS.

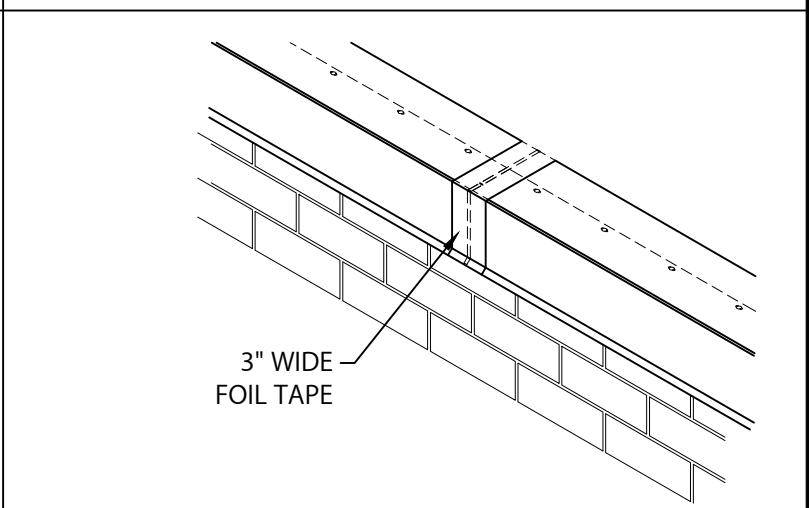

6. FOIL TAPE AT JOINT

PLACE A 3" WIDE PIECE OF FOIL TAPE OVER JOINT.



DRIP EDGE FASCIA

TPO OR PVC VERSION WITH CONTINUOUS CLEAT

NOTE: INSTALL MITERS FIRST

INSTALLATION INSTRUCTIONS

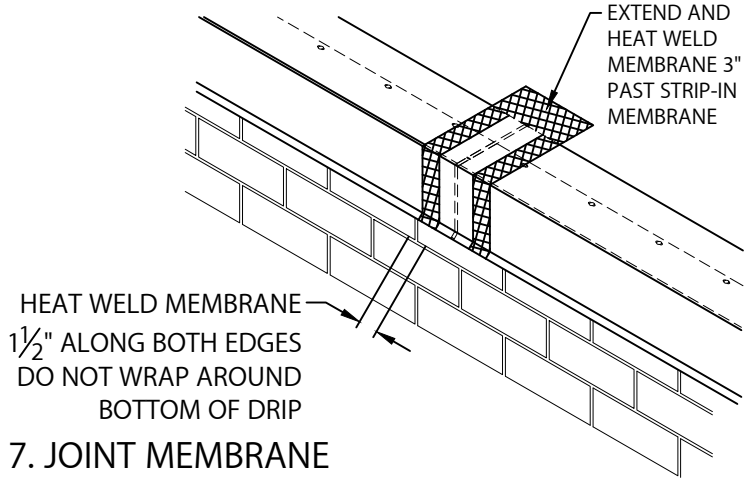

HEAT WELD MEMBRANE 1 1/2" ALONG BOTH EDGES DO NOT WRAP AROUND BOTTOM OF DRIP

7. JOINT MEMBRANE

HEAT WELD A 6" WIDE PIECE OF NON-REINFORCED MEMBRANE OVER JOINT AS SHOWN ABOVE.

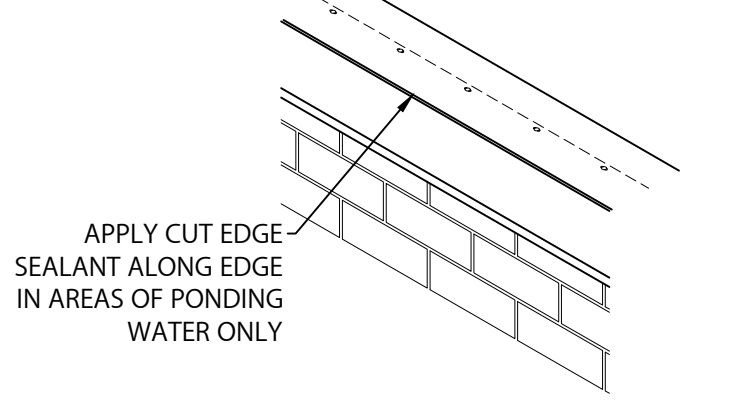

8. SEALANT

APPLY CUT EDGE SEALANT ONLY TO EDGES WHERE PONDING OCCURS.

TYPICAL INSTALLATION

