



ELEVATE EXTENDED SP RADIUS RAIL FASCIA

FULLY ADHERED OR MECHANICALLY ATTACHED SINGLE-PLY VERSION

.050. AND .063" ALUMINUM COVER MATERIAL

IMPORTANT!!! MUST INDICATE PROPER RADIUS CONDITION BY CIRCLING APPROPRIATE OUTSIDE FACE

PROVIDING A RADIUS
THE RADIUS MAY BE PROVIDED
IN ONE OF TWO METHODS:

1.) THE ACTUAL KNOWN RADIUS IS

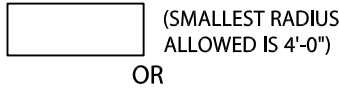

OR

2.) FIELD CONDITION MEASUREMENTS

NOTE: REFER TO ATTACHED WORKSHEET FOR FURTHER INFORMATION

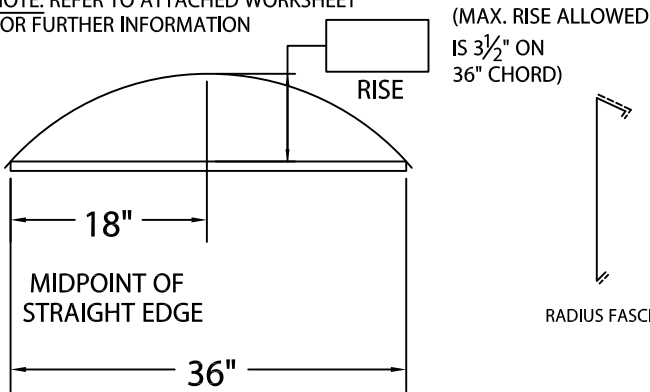

LENGTH OF STRAIGHT EDGE

NOTE: CHECK MEASUREMENTS ALONG ENTIRE RADIUS.

DETAIL A

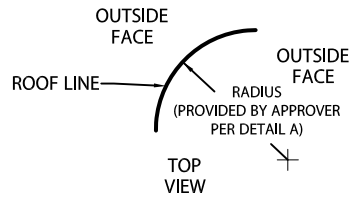

RADIUS FASCIA

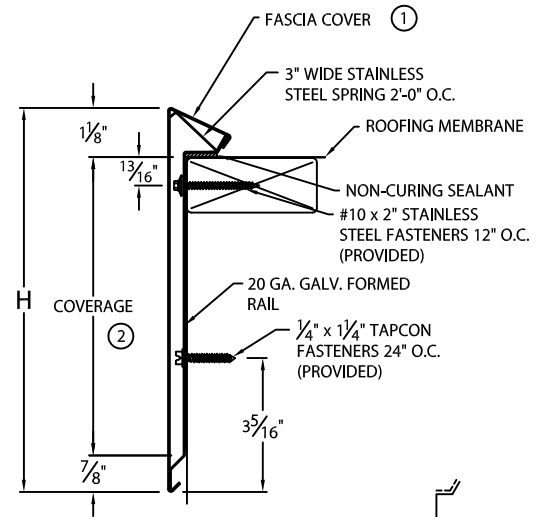

RADIUS FORMED RAIL

----- INDICATES AREA TO BE SLIT TO FORM RADIUS
 OVER 150'-0" RADIUS = NO SLITS
 30'-0" - 150'-0" RADIUS = SLITS 12" O.C.
 16'-0" - 30'-0" RADIUS = SLITS 6" O.C.
 8'-0" - 16'-0" RADIUS = SLITS 3" O.C.
 4'-0" - 8'-0" RADIUS = CUSTOM SLITS 3" O.C.

NOTES:

- ① FASCIA COVER PROVIDED WITH 3 1/2" WIDE SPLICE PLATES.
- ② FACE = COVERAGE (SHOULD EXTEND A MIN. OF 1" BELOW WATERPROOFING MEMBRANE) + 2".

FASCIA DIMENSIONS

PRODUCT ID. NO.	H DIM	COVERAGE
<input type="checkbox"/> ESE-S95	9 1/2"	7 1/2"
<input type="checkbox"/> ESE-S110	11"	9"
<input type="checkbox"/> ESE-S125	12 1/2"	10 1/2"

Fabrication will proceed only after receipt of signed print approval.

Print Approval:

Architect and/or contractor shall verify all dimensions, sizes and quantities. All products to be installed in strict accordance with Elevate's printed instructions.

Approved by: _____

Date: _____

MATERIAL:

___ .050" ALUMINUM

___ .063" ALUMINUM

___ OTHER _____

COLOR: _____

FINISH: _____

QUANTITIES:

_____ LINEAL FEET 12'-0" LENGTHS
 COVER AND RAIL SUPPLIED IN 12'-0" LENGTHS FOR
 16'-0" RADIUS OR GREATER.

COVER AND RAIL SUPPLIED IN 6'-0" LENGTHS FOR
 RADIUS LESS THAN 16'-0".

PROJECT:

ARCHITECT:

ROOFING CONTRACTOR:

REPRESENTATIVE/DISTRIBUTOR:

ELEVATE
 26 CENTURY BLVD.
 SUITE 205
 NASHVILLE, TN 37214
 CONTACT YOU LOCAL ELEVATE REPRESENTATIVE



DATE: 03/13/23

DRN BY: MLM

CKD BY: MM

SHT.# ___ OF ___

DWG# 13010-40438

H