

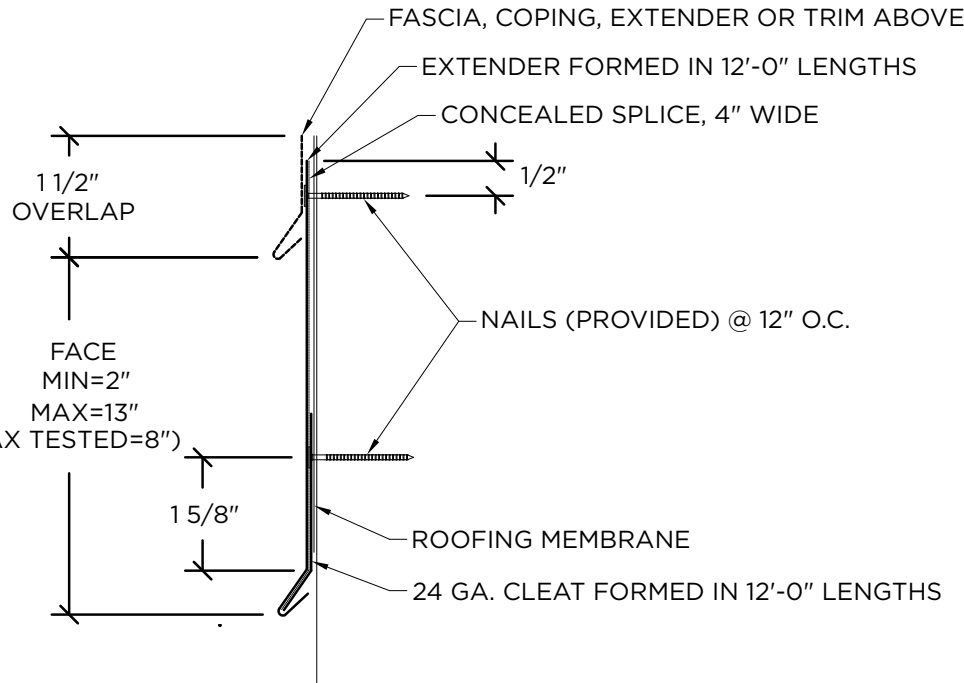

ELEVATE EXTENDER FOR NON-STANDARD HEIGHT

NOTES

- Oil canning can occur on larger face heights and wall widths; recommend 22 Ga..050" or .063" Aluminum for face height over 8".
- Unless otherwise noted, fabrication of miters and accessories are furnished standard utilizing a non-penetrating quicklock joint, then factory sealed watertight.
- Welded accessories require a minimum material thickness of .050"
- For non-90 miters, see separate print approval
- Product should be installed per provided installation instructions
- ANSI/SPRI/FM 4435/ES-1 Test Pressure up to 107 psf



APPROVALS



ANSI/SPRI/FM 4435/ES-1
Test Pressures listed in notes

PROJECT INFO

Project Name: _____

Architect: _____

Roofing Contractor: _____

Project Type:

By selecting this box you have verified and confirmed that dimensions, sizes, and quantities are correct. All products will be installed in strict accordance with printed instructions.

Date: _____

Elevate
26 Century Blvd.
Suite 205
Nashville, TN 37214
Contact your local
Elevate representative.

SHT #: ____ OF ____

DATE: **08/09/23**

DRN BY: **PL**

CKD BY: **MM**

DWG: 13014-10996

REV: **D**

DIMENSIONS

Please Fill Out Dimensions On Drawing

MATERIAL

- 24 Ga. Galv. Steel
- 22 Ga. Galv. Steel
- .040" Aluminum
- .050" Aluminum
- .063" Aluminum
- OTHER: _____

Color: _____

Finish: _____

Substrate: Wood

If substrate is not given, wood fasteners will be provided. Masonry

Metal

QUANTITIES

_____ Lineal Feet (12'-0" Lengths)

_____ Outside Miter (90°)

_____ Inside Miter (90°)

_____ Right Endcaps

_____ Left Endcaps

_____ Right Endwall Flashing

_____ Left Endwall Flashing

Accessory Type:

Quicklock (Default)

Welded (Surcharge)

NOTES

- Standard miter angle is 90 degrees
- For special miter requirements, attach sketches or consult manufacturer for assistance.

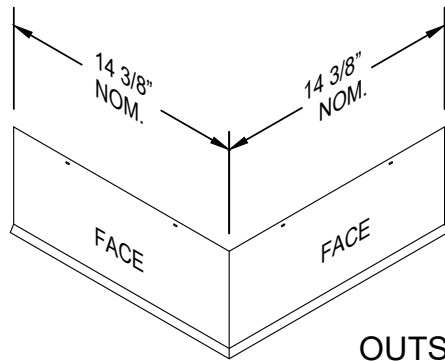
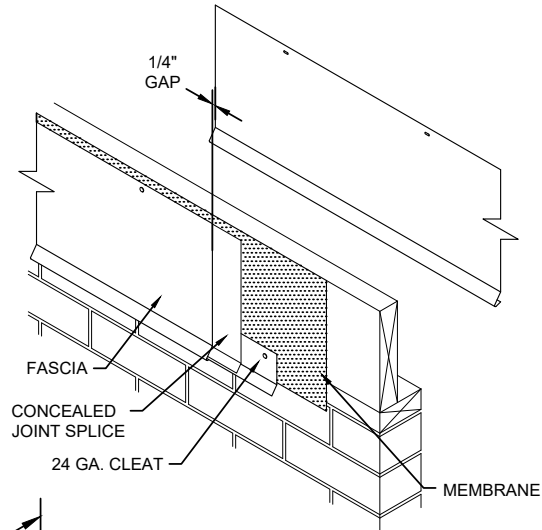

OUTSIDE MITER

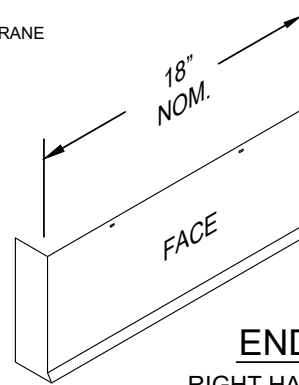

ENDCAP
RIGHT HAND SHOWN

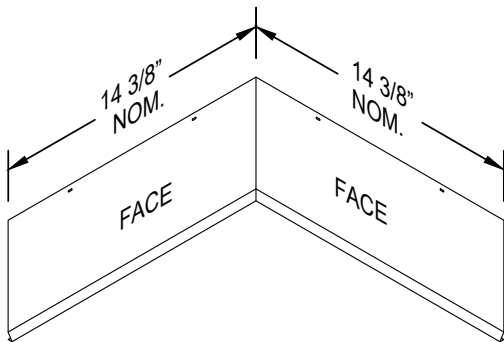

INSIDE MITER

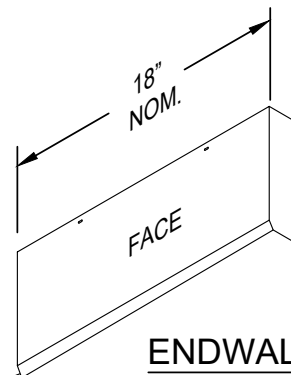

ENDWALL FLASHING
LEFT HAND SHOWN

SHT #: ____ OF ____

DATE: **08/09/23**

DRN BY: **PL**

CKD BY: **MM**

DWG: 13014-10996

REV: **D**

Elevate
26 Century Blvd.
Suite 205
Nashville, TN 37214
Contact your local
Elevate representative.