



FORMED TERMINATION BAR

FORMED BAR WITH COVER

NOTES

- Cover provided with lap joints
- ANSI/SPRI/FM 4435/ES-1 Test Pressure up to 360 psf

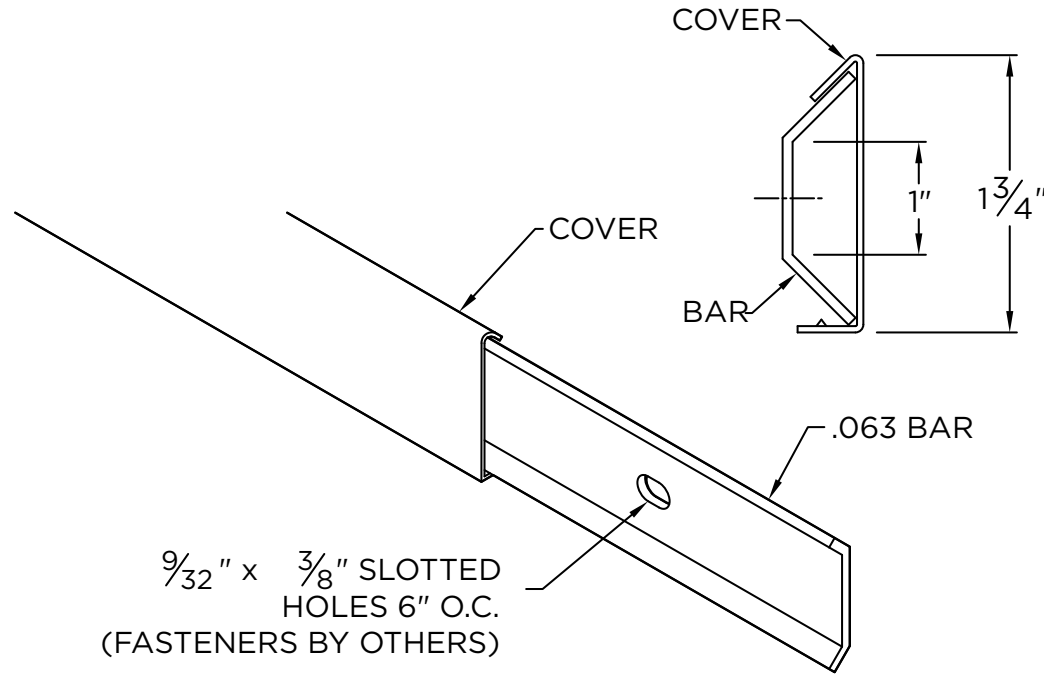

APPROVALS

ANSI/SPRI/FM 4435/ES-1
Test Pressures listed in notes

PROJECT INFO

Project Name: _____

Architect: _____

Roofing Contractor: _____

Project Type:

By selecting this box you have verified and confirmed that dimensions, sizes, and quantities are correct. All products will be installed in strict accordance with printed instructions.

Date: _____

Carlisle SynTec Systems
Customer Service
866-458-3537
(Metal-Era)

SHT# 1 of 1

DATE: SSSSSSSSSS

DRN BY: JJC

CKD BY: MM

8K ; . SSSSSSSSSS

F 9J . SSSSSSSSSS

MATERIAL

Bar Material (CB-175F): .063 Aluminium

Cover Material (CF-175F):

- 24 Ga. Galv. Steel Color: _____
- .040" Aluminum Finish: _____

QUANTITIES

_____ Bar Lineal Feet (12'-0" Lengths)

_____ Cover Lineal Feet (12'-0" Lengths)