

# MOUNTING ANGLE

FOR USE WITH WIND RESISTANT XL GUTTER

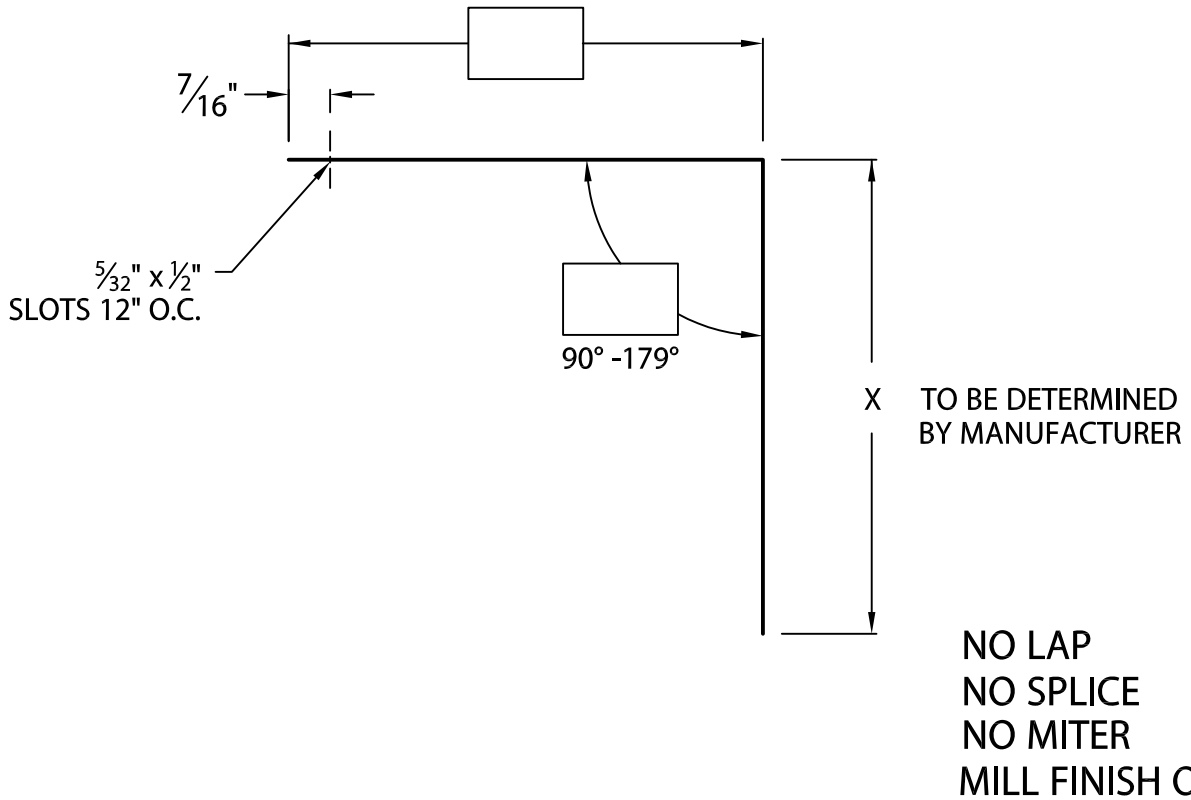

Fabrication will proceed only after receipt of signed print approval.

## Print Approval:

Architect and/or contractor shall verify all dimensions, sizes and quantities. All products to be installed in strict accordance with printed instructions.

Approved by: \_\_\_\_\_

Date: \_\_\_\_\_

FRONT AND BOTTOM HEIGHT	MATERIAL
<input type="checkbox"/> 8" <input type="checkbox"/> 9"	.063" ALUMINUM
<input type="checkbox"/> 10" <input type="checkbox"/> 11"	.080" ALUMINUM
<input type="checkbox"/> 12" <input type="checkbox"/> 13"	.100" ALUMINUM
<input type="checkbox"/> 14"	.125" ALUMINUM

### QUANTITIES:

\_\_\_\_\_ LINEAL FEET 12'-0" LENGTHS

PROJECT:	Hickman Edge Systems		
ARCHITECT:	4 Commerce Way		
ROOFING CONTRACTOR:	Arden, NC 28704		
REPRESENTATIVE/DISTRIBUTOR:	Phone: 828-676-1700		
	www.hickmanedgesystems.com		
 <p>HICKMAN an MTL company</p>	DATE: 07/27/23	SHT.# ____ OF ____	
	DRN BY: MLM		
	CKD BY: MM	DWG# 64018-41197	<b>A</b>