



THRU-WALL SCUPPER

STYLE 3 WELDED RAISED COLLECTOR BOX

NOTES

- Product should be installed per provided installation instructions

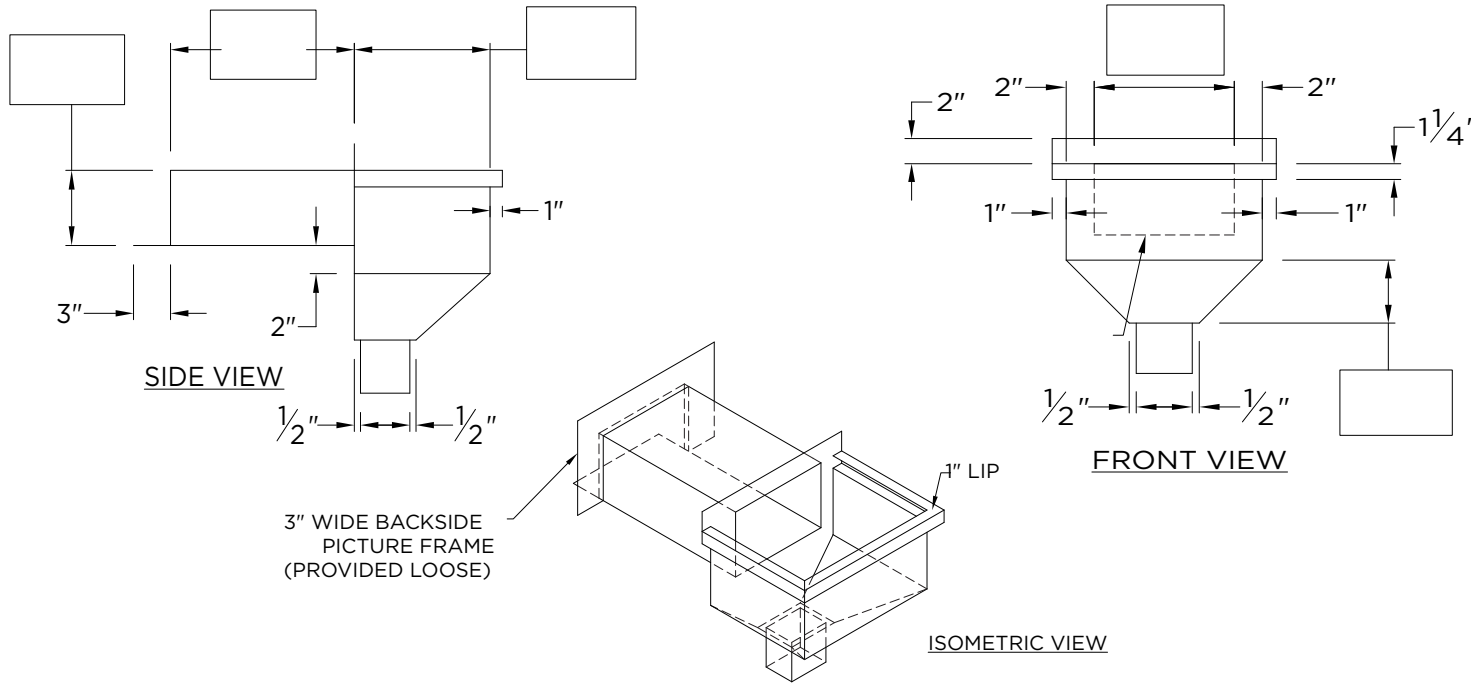

PROJECT INFO

Project Name: _____

Architect: _____

Roofing Contractor: _____

Project Type:

By selecting this box you have verified and confirmed that dimensions, sizes, and quantities are correct. All products will be installed in strict accordance with printed instructions.

Date: _____

Carlisle SynTec Systems
Customer Service
866-458-3537
(Metal-Era)

SHT# 1 of 1

DATE: 12/18/23

DRN BY: JJC

CKD BY: MM

DWG #: 15018-39999

REV: B

DIMENSIONS

PLEASE FILL OUT DIMENSIONS ON DRAWING

MATERIAL

.063" Aluminum

Color: _____

Finish: _____

QUANTITIES

_____ Amount Required

Downspout Size _____ x _____

(Quantities Over 15 Require Extended Lead Time Due to Post Coating Process)