

# PERMASPAN RR 3-AXIS EXPANSION JOINT

ROOF TO ROOF VERSION WITH 3 AXIS MOVEMENT

INSTALLATION INSTRUCTIONS

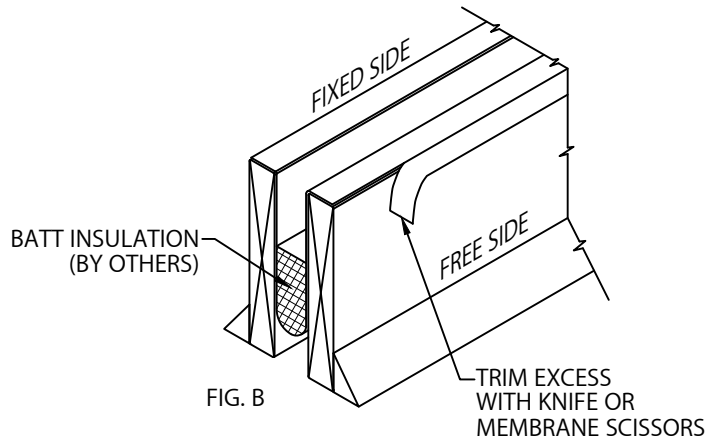
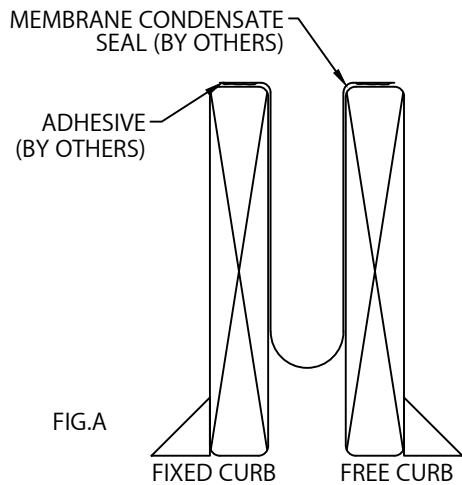

## 1. Condensation Seal

Begin the expansion joint installation by first inserting the condensation seal (by others) into the expansion joint gap between the curbs, extending the pocket to a depth at least equal to the width of the expansion joint, more if allowable. Lap 6" and seal all membrane joints. Fold in the ends of the membrane seal and secure to the wood curb with adhesive (by others), applying to curb and membrane condensate seal, to temporarily hold the membrane in place (Fig. A). Trim membrane to be even with the outside edges of the curbs, if necessary (Fig. B). Insert the insulation (by others) with the system into the pocket of the membrane.

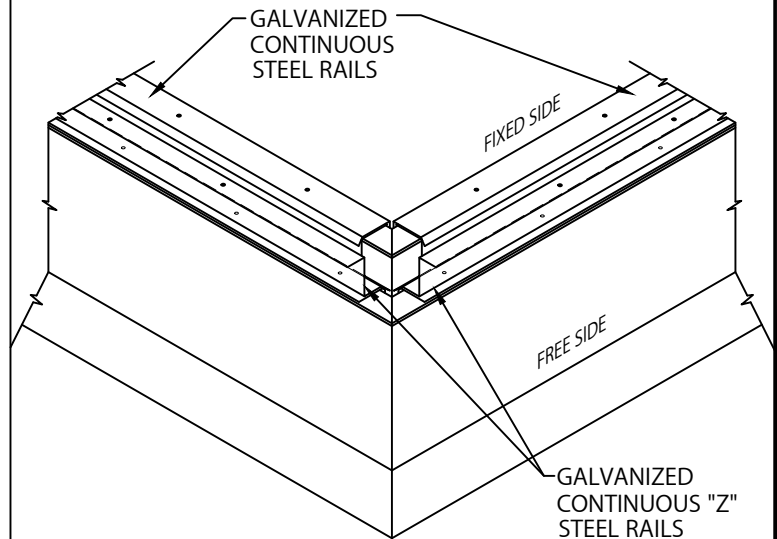
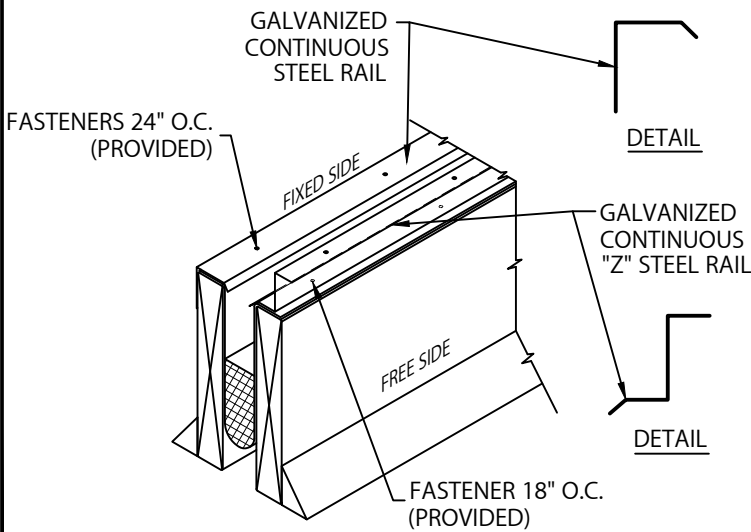

## 2. Continuous Rails

Position the galvanized steel rail on top of the fixed wood curbs. Fasten steel rail to the top of the wood curb at 24" O.C. with provided fasteners. Position the galvanized steel "Z" rail on top of the free wood curb. Fasten steel "Z" rail to the top of the wood curb at 18" O.C. with provided fasteners.

## 3. Miters

Field cut curbs at a 90° angle as shown. Follow steps 1 and 2, installing condensation seal, batt insulation and continuous rails.

# PERMASPAN RR 3-AXIS EXPANSION JOINT

ROOF TO ROOF VERSION WITH 3 AXIS MOVEMENT

## INSTALLATION INSTRUCTIONS

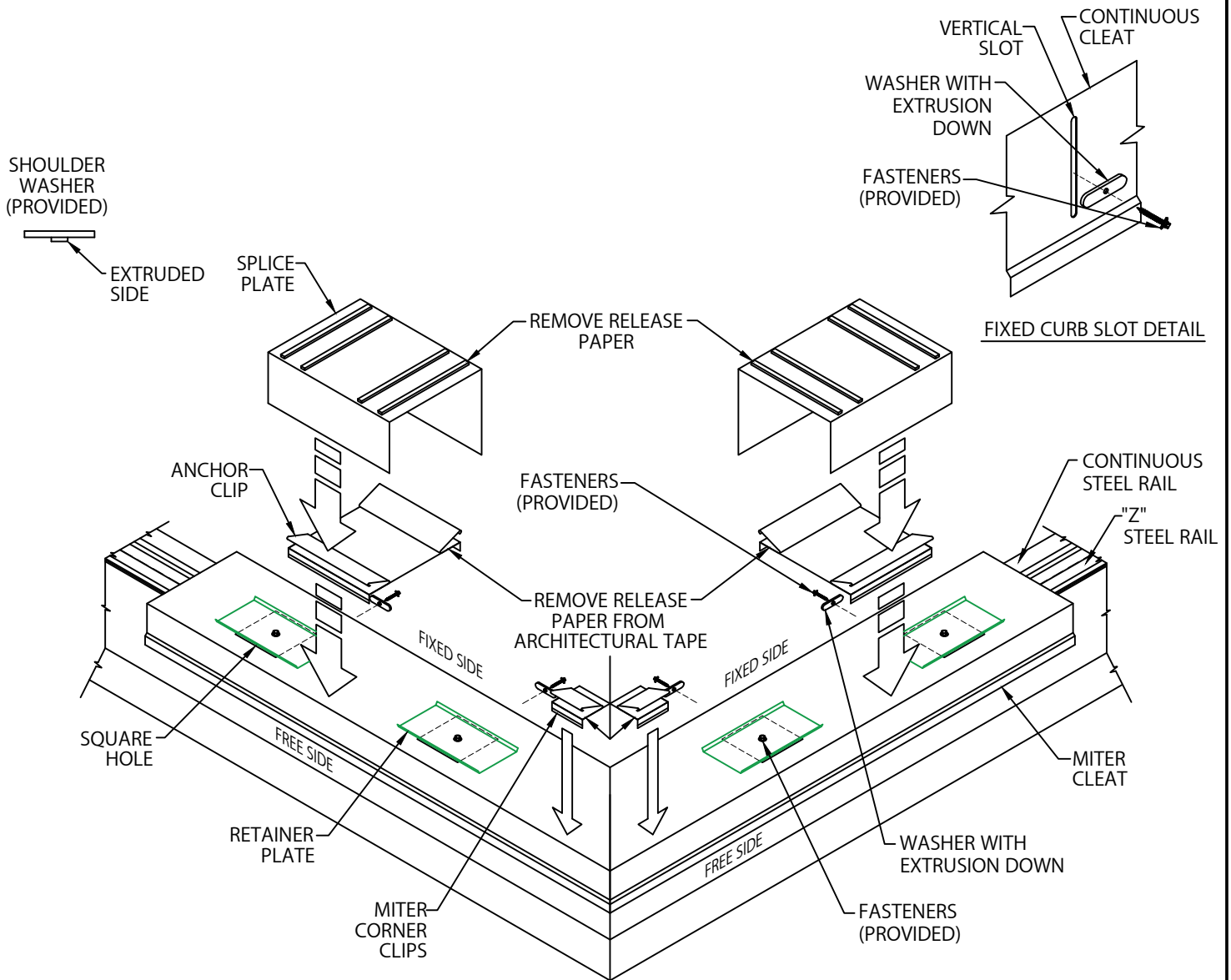

### 4. Miters

Lay the miter cleat in place over the expansion joint curbs. Place the miter cleat so the fixed side of the cleat is flush with the side of the fixed curb. The cleat overhangs curbs noted as free side, which is also the same side as the square holes in the cleat. Secure the continuous cleat with fasteners and shouldered washers provided into the vertical slots on the side of the continuous cleat. The washers are to be placed extruded side down in approximately the center of the vertical slots (See Slot Detail). Secure the continuous cleat to the free curb with fasteners. Fasten through the provided retainer plates, centered in the square holes of the continuous cleat. Remove release paper from architectural tape located on bottom of anchor clips and miter corner clips. Place galvanized miter corner clips on cleat as shown. Center 8" wide anchor clips between square holes. Center 12" splice plate onto anchor clips as shown. Remove release paper from top of factory applied sealant strips.

DO NOT OVERDRIVE THE SCREWS INTO THE CLEAT SO THAT THE SCREWS DO NOT RESTRICT MOVEMENT.

# PERMASPAN RR 3-AXIS EXPANSION JOINT

ROOF TO ROOF VERSION WITH 3 AXIS MOVEMENT

INSTALLATION INSTRUCTIONS

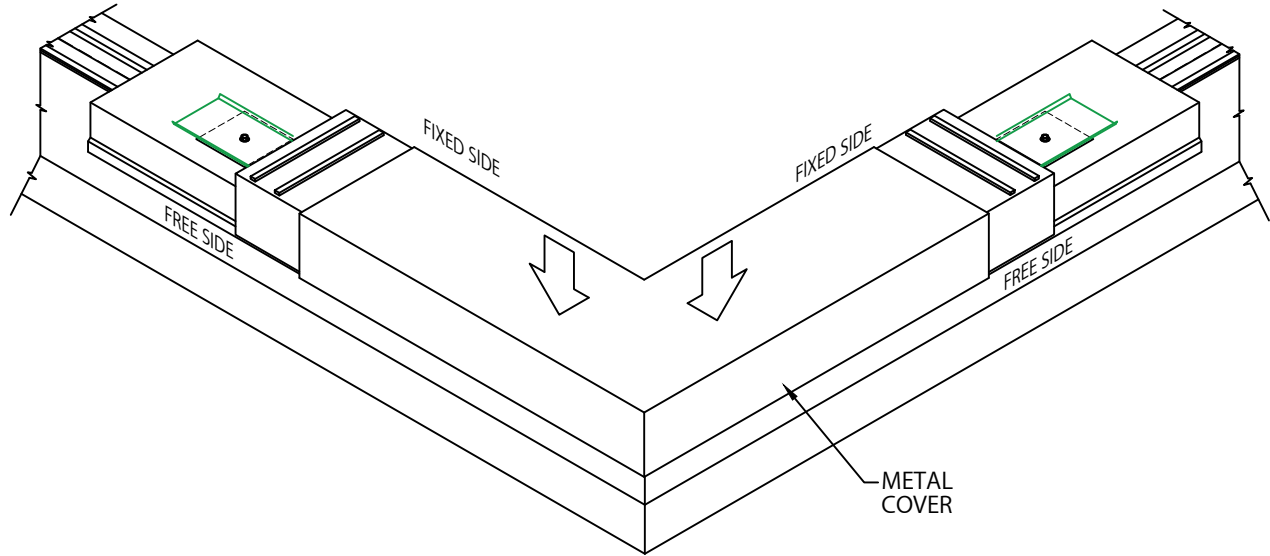

## 5. Miters

Press miter cover straight down into place. Continue downward pressure until snap lock occurs on both legs.

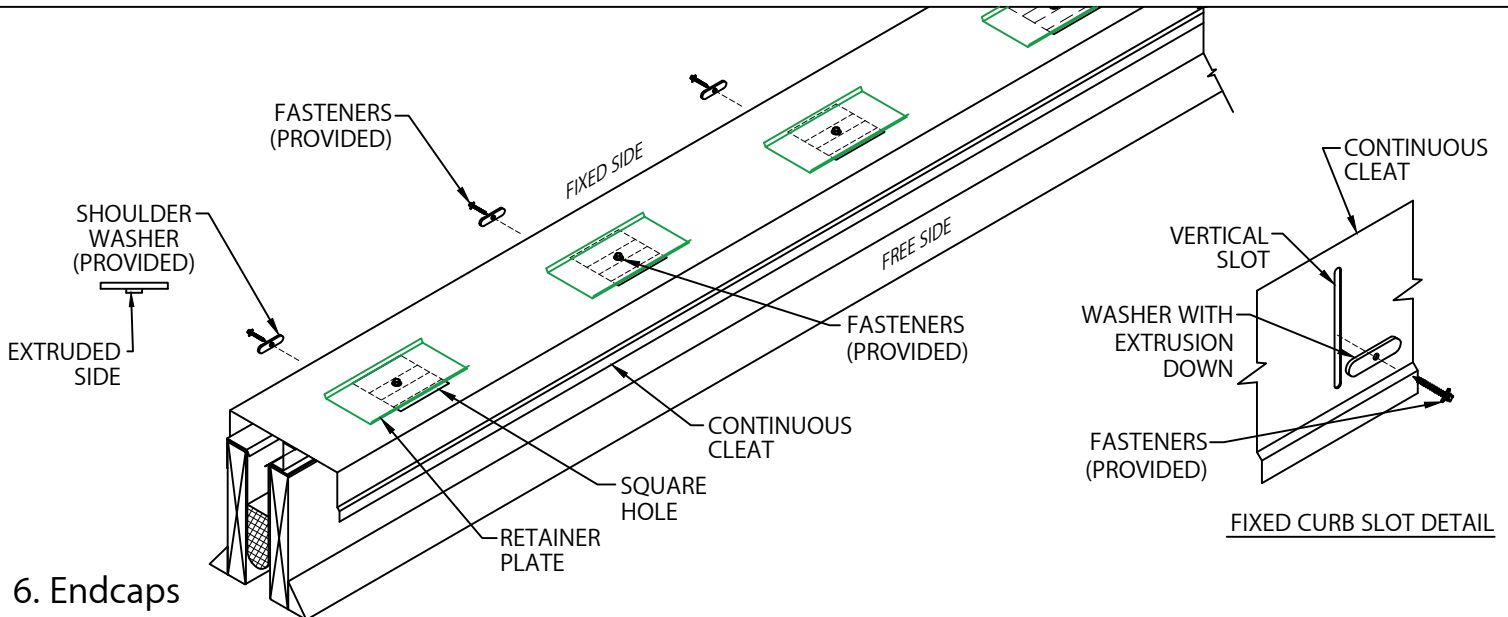

## 6. Endcaps

Place continuous cleat over the expansion joint curbs. If this step was preceded by installing a miter, the square holes must be centered over the continuous "Z" cleat. The cleat should extend beyond the free side of the expansion joint with the square holes centered on the continuous "Z" cleat. Secure the continuous cleat with fasteners and shouldered washers provided with the system. The washers are to be placed extruded side down in approximately the center of the vertical slots on the side of the fixed curb (See Slot Detail). Secure the continuous cleat to the free curb with fasteners. Fasten through provided retainer plates, centered in the square holes of the continuous cleat.

DO NOT OVERDRIVE THE SCREWS INTO THE CLEAT SO THAT THE SCREWS DO NOT RESTRICT MOVEMENT.

# PERMASPAN RR 3-AXIS EXPANSION JOINT

ROOF TO ROOF VERSION WITH 3 AXIS MOVEMENT

INSTALLATION INSTRUCTIONS

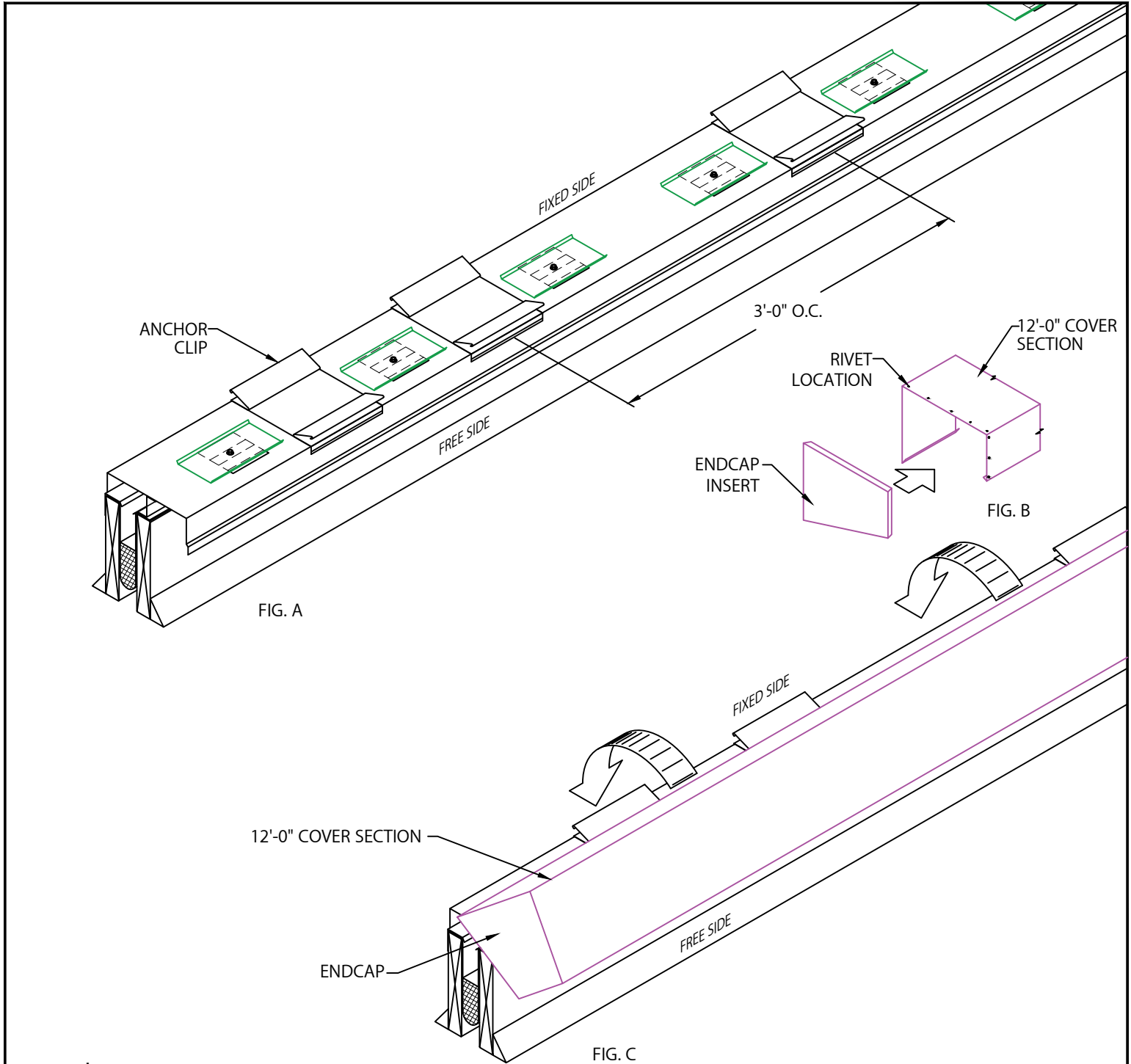

## 7. Endcap Inserts

Remove release paper from architectural tape located on bottom of anchor clips. Center 6" wide anchor clips between first and second square hole (Fig. A). Place additional anchor clips 3'-0" O.C., placing a splice plate onto anchor clip at splice joint. Place endcap insert into 12'-0" cover section (Fig. B). Pop rivet (not provided) insert into place and seal tight using non-curing sealant (not provided) on inside along seams. Hook endcap section on the free side of the continuous cleat and rotate into place (Fig. C). Engage rear leg onto continuous cleat by pressing downward until snap lock occurs.

# PERMASPAN RR 3-AXIS EXPANSION JOINT

ROOF TO ROOF VERSION WITH 3 AXIS MOVEMENT

## INSTALLATION INSTRUCTIONS

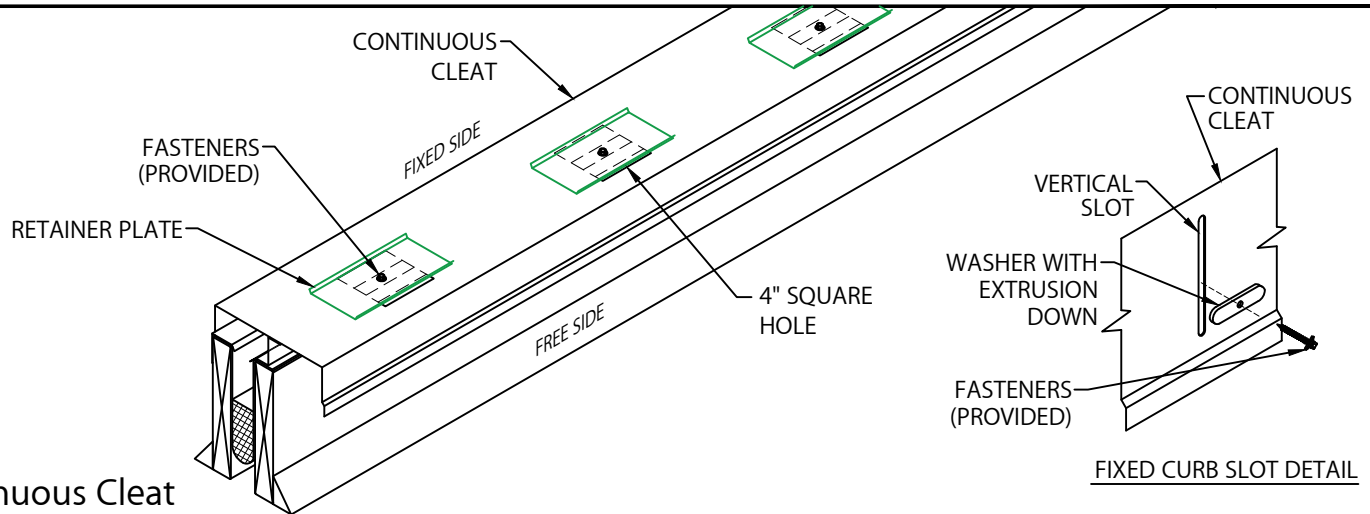

### 8. Continuous Cleat

Place continuous cleat over the expansion joint curbs. If this step was preceded by installing a miter, the square holes must be centered over the continuous "Z" cleat. The cleat should extend beyond the free side of the expansion joint. Secure the continuous cleat with fasteners and shouldered washers provided with the system. The washers are to be placed extruded side down in approximately the center of the vertical slots on the side of the fixed curb (See Slot Detail). Secure the continuous cleat to the free curb with fasteners. Fasten through provided retainer plates, centered in the square holes of the continuous cleat.

**DO NOT OVERDRIVE THE SCREWS  
INTO THE CLEAT SO THAT THE SCREWS  
DO NOT RESTRICT MOVEMENT.**

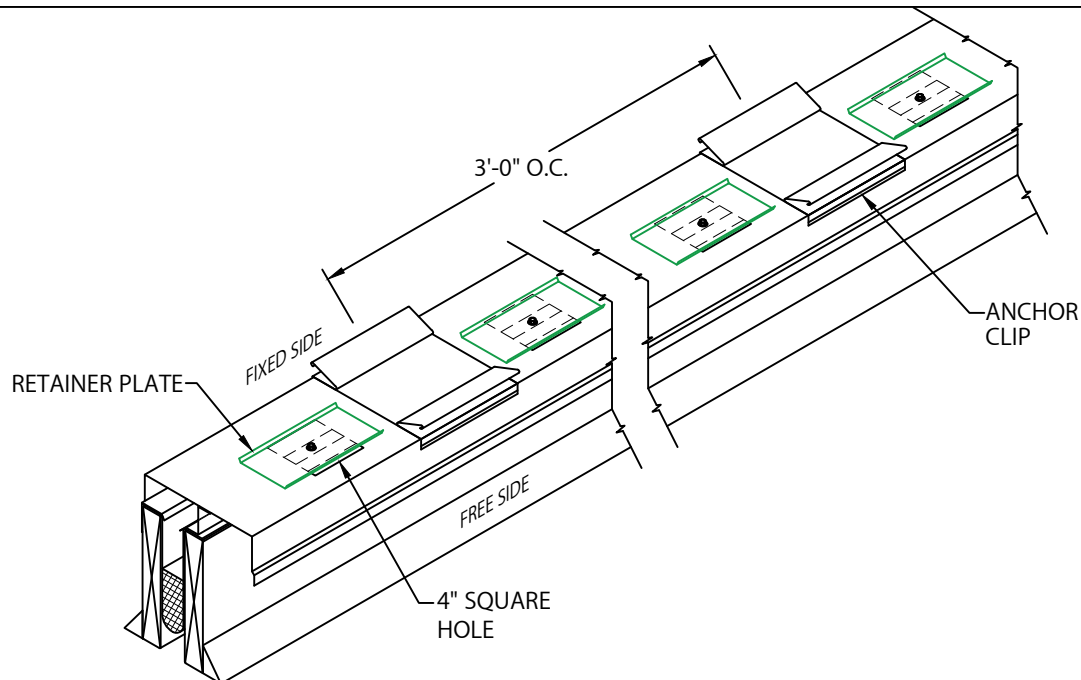

### 9. Anchor Clips

Remove release paper from architectural tape located on bottom of anchor clips. Center 6" wide anchor clip between square holes as shown. Continue placing anchor clips 3'-0" O.C.

# PERMASPAN RR 3-AXIS EXPANSION JOINT

ROOF TO ROOF VERSION WITH 3 AXIS MOVEMENT

INSTALLATION INSTRUCTIONS

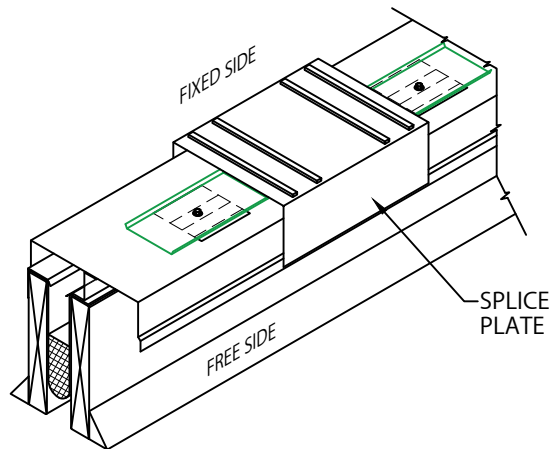

## 10. Splice Plates

Center splice plate onto anchor clips at splice joints, 12'-0" O.C.

NOTE: Remove release paper from sealant strips.

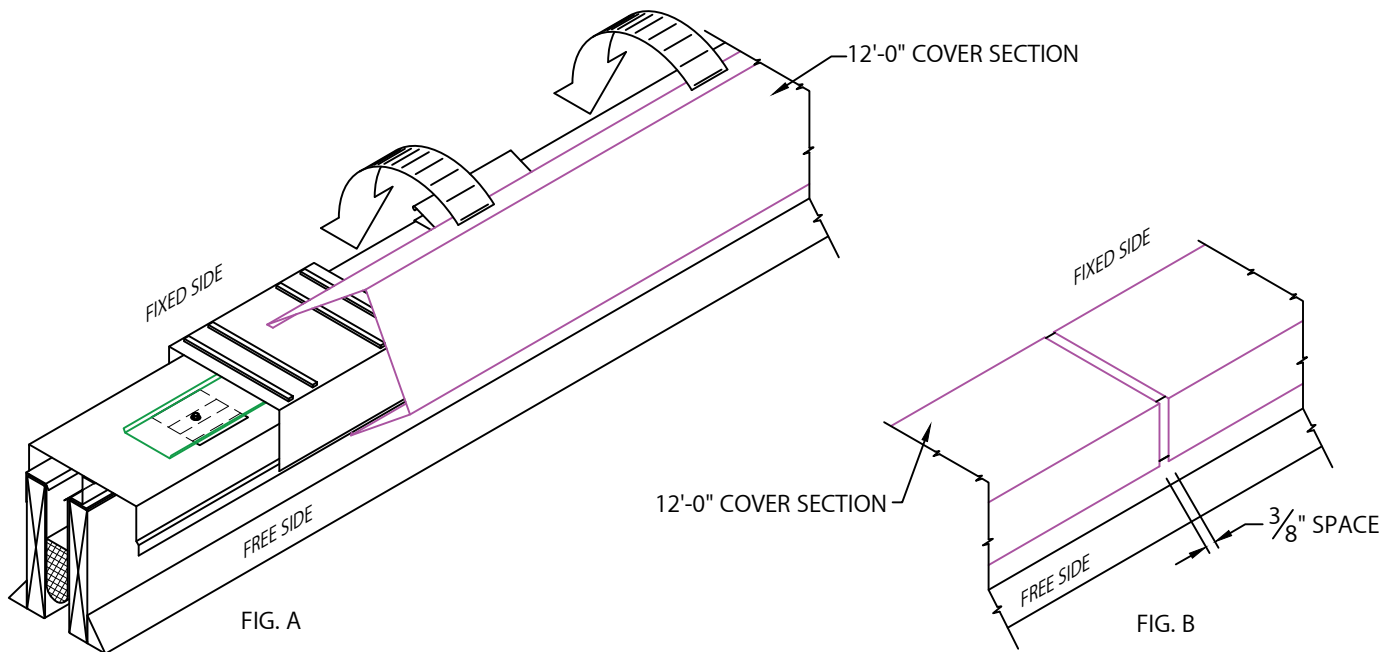

## 11. Expansion Joint Cover

Install the cover sections onto the continuous cleats. Hook cover section on the free side of the continuous cleat and rotate into place (Fig. A). Engage rear leg onto continuous cleat by pressing downward until snap lock occurs. Continue installing cover with a 3/8" space at splice joints to allow for thermal expansion (Fig. B). Field cut where necessary using a fine tooth hacksaw or snips.

NOTE: Remove protective film immediately.

# PERMASPAN RR 3-AXIS EXPANSION JOINT

ROOF TO ROOF VERSION WITH 3 AXIS MOVEMENT

INSTALLATION INSTRUCTIONS

## TYPICAL INSTALLATION

