

# WELDED CONDUCTOR HEAD-2

## NOTES

- Product should be installed per provided installation instructions

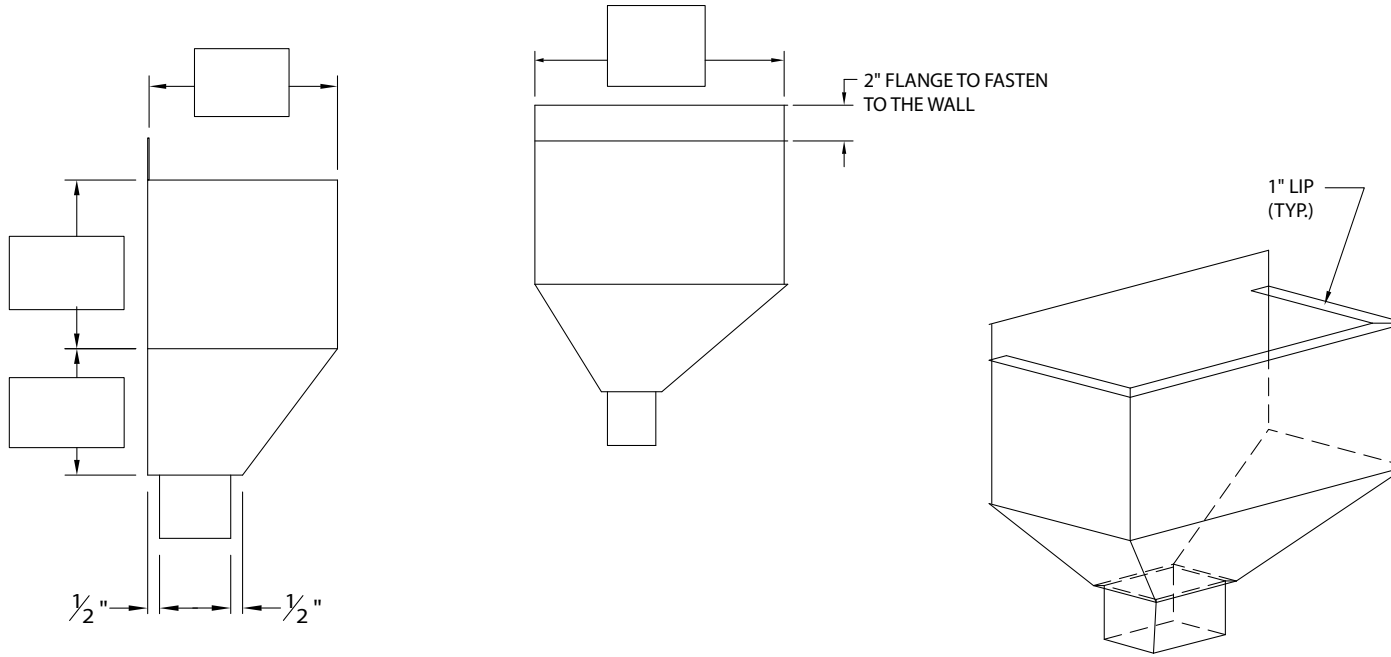

## DIMENSIONS

PLEASE FILL OUT DIMENSIONS ON DRAWING

## MATERIAL

.063" Aluminum

Color: \_\_\_\_\_

Finish: \_\_\_\_\_

## PROJECT INFO

Project Name: \_\_\_\_\_

Architect: \_\_\_\_\_

Roofing Contractor: \_\_\_\_\_

### Project Type:

By selecting this box you have verified and confirmed that dimensions, sizes, and quantities are correct. All products will be installed in strict accordance with printed instructions.

Date: \_\_\_\_\_

### Hickman Edge Systems

4 Commerce Way  
Arden, NC 28704  
Phone: 828-676-1700  
www.hickmanedgesystems.com

SHT# 1 of 1

DATE: 01/22/ 22

DRN BY: JJC

CKD BY: MM

DWG #: 64018-36806

REV: A

## QUANTITIES

\_\_\_\_\_ Amount Required

Downspout Size \_\_\_\_\_ x \_\_\_\_\_

(Quantities Over 15 Require Extended Lead Time Due to Post Coating Process)